

Variable speed drives Altivar 310L

For applications from 0.75 to 5.5 kW / 1 to 7.5 HP

Catalog

January 2019



Introducing the **Easy line**

Essential automation & control products

When just enough is just right!

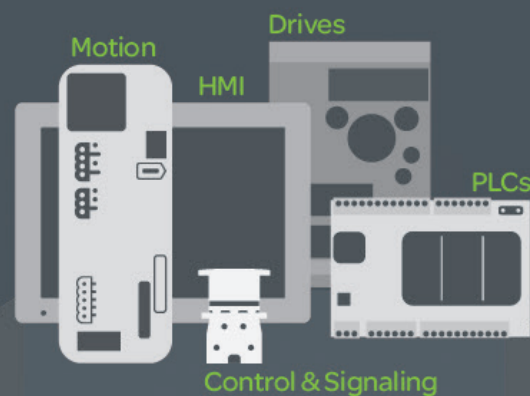

Schneider
Electric

General contents

Altivar 310L variable speed drives

| | |
|--|---------|
| ■ Variable speed drives | page 2 |
| □ Presentation | page 2 |
| □ Applications | page 2 |
| □ Functions | page 2 |
| □ An optimized offer | page 3 |
| □ Characteristics and functions of the control terminals | page 4 |
| □ References | page 5 |
| ■ Configuration tools | page 6 |
| □ Simple Loader and Multi-Loader | page 6 |
| ■ Options | page 7 |
| □ Line chokes, motor chokes and LR filter cells | page 7 |
| □ Braking resistors | page 8 |
| □ Spare parts | page 8 |
| ■ Motor starters | page 9 |
| ■ Product reference index | page 10 |



Conveyor application

Presentation

The Altivar™ 310L drive is a frequency inverter for three-phase 380...460 V asynchronous motors rated from 0.75 kW/1 HP to 5.5 kW/7.5 HP.

The all in one robust design of this drive, its ease of installation, based on the principle of Plug & Play, its integrated functions and macro configuration make it particularly suitable for decentralized applications in the material handling segment, specially conveyor and sorting machines.

By taking account of the constraints governing installation and use at the product design stage, we have been able to offer a reliable, cost-effective solution to manufacturers of OEM machines.

The Altivar 310L has been developed with no compromise on quality : the components are designed to last 10 years.

Applications

The Altivar 310L incorporates functions that are suitable for material handling, covering both conveyor and sorting applications.

Functions

In addition to the functions usually available on this type of drive, the Altivar 310L drive also features the following:

Motor control functions (1)

- Motor control profiles:
 - Performance: Vector control
 - Standard: U/F 2 points
 - Quadratic load: U²/F
- Cooling fan thermal control
- Switching frequency management
- Boost torque
- Motor noise reduction
- Current limitation
- Auto DC injection

Application functions (1)

- Frequency skip
- Preset speeds
- S ramp, U ramp, ramp switching
- Jog operation
- +/- speed around reference
- Freewheel stop, fast stop
- Automatic catching a spinning load with speed detection and automatic restart
- Brake logic function

Control functions (1)

- Channel configuration - Start/Stop, Local mode, Remote mode
- Reference channel selection
- Reverse inhibition
- Force local control
- Store customer parameter settings

Protection and maintenance functions (1)

- Protection of the installation by means of underload and overload detection
- Maintenance functions:
 - HMI password
 - Configuring the logic I/O
 - Configuring how the parameters are displayed
 - Viewing the state of the logic inputs on the drive display
 - Key parameters display (drive power on / Fan time / Process elapsed time)
 - The last 4 fault display, error log, etc.

(1) For the implementation of functions, please consult the user manual on our local website.



Sorting application

An optimized offer

Environment

The entire range conforms to international standards IEC/EN 61800-5-1 and IEC/EN 61800-3 and has been developed to meet the requirements of directives regarding the protection of the environment (RoHS, WEEE). Owing to its innovated air flow design and to its thicker coating which avoids polluting PCB, the range can be used in the harshest environments. It can withstand a 45 °C/113 °F ambient air temperature around the device without derating (1). Its degree of protection is IP 54.

Adaptability and performances

The Altivar 310L has been designed with an increased adaptability to different motors and various tough loads.

One of its main quality is its torque capacity for starting and braking:

- Braking capacity:
 - over 80 % of the rated motor torque without braking resistor
 - 150 % of the rated motor torque with braking resistor (see page 6)
- Torque capacity
 - starting torque 150 % at 3 Hz
 - over torque : 150 to 170 %, depending on model (2).

Easy to integrate in system

The Altivar 310L drive integrates as standard the AS-i communication protocol, which can be accessed via the M12 connector located on the underside of the drive. AS-i is a field bus over which IO, speed reference, VSD state and alarm information circulates. For more information on the complementary characteristics of AS-i port (address, single/dual mode, ...), please consult our local website. Customer can address AS-i through AS-i addressing port or through the parameter setting.

Easy to install

All ATV 310L use the same installation size in order to standardize customer's system and installation hole. The Altivar 310L drives can easily and quickly be installed as:

- they are easy and quick to wire due to their Plug & Play concept. Power input and output used heavy duty connectors, and Logic input/output used M12 connectors.
- they can be identified on the front panel.

Easy to commission

Simple Loader and Multi-Loader configuration tools

The Simple Loader tool enables one powered-up drive's configuration to be duplicated on another powered-up drive. Operation is very simple.

The Multi-Loader tool enables configurations from a PC or drive to be copied and duplicated on another drive.

Easy to maintain

A warning is sent by the drive to the user when it is necessary to clean heat sink or replace cooling fan.

The security of the system is ensured by an access code allowing authorized people to configure applications and settings in Configuration mode. Simple users are only allowed to use the Monitoring mode (parameters display).

Load Switch

When the load switch is set to OFF, all power to the motor is terminated then the motor can be repaired or replaced as required.

HMI, communication and connectors

- LED display with buttons (MODE, ESC, UP, OK, DOWN, REV, STOP/RESET, FWD)
- Heavy duty connector
- M12 connector
- AS-i topology
- 4 logic inputs and 2 logic outputs

(1) Over this temperature, see the derating curves in the User Manual, available on our website.

(2) For more information, please refer to our local website.



Simple-Loader configuration tool



Multi-Loader configuration tool

Characteristics and functions of the control terminals

| Terminal | Function | Electrical characteristics |
|--------------------------|--|---|
| 0 V or COM | Common of the logic I/Os | |
| LO1 LO2 | Common of the logic outputs (emitter) | <ul style="list-style-type: none"> ■ Rated Voltage: 24 VDC ■ Power supply input range: 19.2V-28.8 VDC ■ Power supply reverse protection ■ Current: 0.5 A ■ Response time: 2 ms ■ Insulation resistance: >10 MΩ ■ Residual voltage: <15 V at 0.1 A ■ Impedance: 80 Ω |
| LI1 LI2 LI3 LI4 | Logic inputs | <p>Programmable logic inputs, comply with IEC/EN 61131-2 logic type 1</p> <ul style="list-style-type: none"> ■ + 24 VDC power supply (maximum 30 V) ■ Impedance: 3.5 kΩ ■ State: 0 if ≥ 15 V ■ State: 1 if ≤ 10 V ■ sampling time: < 8 ms ± 0.7 ms |
| + 24 V | + 24 VDC supply provided by the AS-i communication via the drive | + 24 VDC -15% +20% protected against short-circuits and overloads. Maximum customer current available: 100 mA |
| AS-i+ | AS-i positive | <ul style="list-style-type: none"> ■ Nominal bus supply voltage: 30 VDC ■ AS-i voltage 26.5 VDC to 31.6 VDC ■ Auxillary power supply: 19.2 V to 28.8 VDC ■ Power consumption of AS-i voltage: ≤ 50 mA (+ output currents) |
| AS-i- | AS-i negative | |
| AUX24 V | Auxiliary 24 V | |
| AUX0 V | Auxiliary 0 V | |

Variable speed drives

Altivar 310L Drives

ATV310L_658F13_CPMGU18001



Heatsink drives:
ATV310L075N4...U30N4

ATV310L_658F13_CPMGU18002



Ventilated drives:
ATV310LU40N4, ATV310LU55N4

| Drives | | | | | | | | | | |
|---|-----------------------|-------|----------------|------|---------------------------|--|------------------------------------|---|--------------|------------------|
| Motor | Line supply | | | | | Altivar 310 | | | | |
| Power indicated on rating plate (1) | Max. line current (2) | | Apparent power | | Max. prospective line Isc | Maximum continuous output current (In) (1) | Maximum transient current for 60 s | Dissipated power at maximum output current (In) (1) | Reference | Weight (3) |
| | 380 V | 460 V | 460 V | | | | | | | |
| kW | HP | A | A | kVA | kA | A | A | W | | kg/ lb |
| Three-phase supply voltage: 380...460 V 50/60 Hz | | | | | | | | | | |
| 0.75 | 1 | 3.5 | 3.1 | 2.5 | 5 | 2.3 | 3.5 | 28.83 | ATV310L075N4 | 6.900/ 15.211 |
| 1.5 | 2 | 6.5 | 5.4 | 4.3 | 5 | 4.1 | 6.2 | 51.82 | ATV310LU15N4 | 6.900/ 15.211 |
| 2.2 | 3 | 8.8 | 7.2 | 5.7 | 5 | 5.5 | 8.3 | 66.32 | ATV310LU22N4 | 6.900/ 15.211 |
| 3 | 4 | 11.1 | 9.2 | 7.3 | 5 | 7.1 | 10.7 | 80.24 | ATV310LU30N4 | 6.900/ 15.211 |
| 4 | 5 | 13.7 | 11.4 | 9.1 | 5 | 9.5 | 14.3 | 102.72 | ATV310LU40N4 | 7.400/ 16.314 |
| 5.5 | 7.5 | 21.3 | 14.3 | 11.4 | 5 | 12.6 | 18.9 | 141.54 | ATV310LU55N4 | 7.400/ 16.314 |
| Dimensions (overall) | | | | | | | | | | |
| Drives with heatsinks | | | | | W x H x D | | | | | |
| | | | | | mm | | | | | |
| | | | | | in. | | | | | |
| ATV310L075N4, ATV310LU15N4, ATV310LU22N4, ATV310LU30N4 | | | | | 445 x 210 x 171 | | | | | |
| | | | | | 17.52 x 8.26 x 6.73 | | | | | |
| Drives with ventilation | | | | | W x H x D | | | | | |
| | | | | | mm | | | | | |
| | | | | | in. | | | | | |
| ATV310LU40N4, ATV310LU55N4 | | | | | 445 x 210 x 191 | | | | | |
| | | | | | 17.52 x 8.26 x 7.52 | | | | | |

(1) These values are given for a nominal switching frequency of 4 kHz, for use in continuous operation. If operation above 4 kHz needs to be continuous, the nominal drive current should be derated by 10% for 8 kHz and 20% for 12 kHz. The switching frequency can be set between 2 and 12 kHz for all ratings. Above 4 kHz, the drive will reduce the switching frequency automatically in the event of an excessive temperature rise. See the derating curves in the User Manual, available on our local website.

(2) Typical value for the indicated motor power and for the maximum prospective line Isc.

(3) Weight of product without packaging.

| Configuration tools | | | |
|---|--------------|-----------|---------------------|
| Description | For drives | Reference | Weight kg/ lb |
| Simple Loader, Multi-Loader configuration tools and associated cable | | | |
| Simple Loader tool For duplicating one drive configuration on another drive. The drives must be powered-up. The tool is supplied with a cordset equipped with 2 RJ45 connectors. | ATV310L●●●N4 | VW3A8120 | – |
| Multi-Loader tool For copying a configuration on a PC or drive and duplicating it on another drive. The drives do not need to be powered-up. Supplied with the tool: <ul style="list-style-type: none"> ■ 1 cordset equipped with 2 RJ45 connectors ■ 1 cordset equipped with a USB type A connector and a USB Mini-B type connector ■ 1 x 2 GB minimum SD memory card ■ 1 female/female RJ45 adaptor ■ 4 AA/LR6 1.5 V batteries | ATV310L●●●N4 | VW3A8121 | – |

Presentation

Line chokes

A line choke can be used to provide improved protection against overvoltages on the line supply and to reduce harmonic distortion of the current produced by the drive. They are recommended for ATV310L...N4 drives. The recommended chokes limit the line current. They have been developed in line with standard EN 50178 (VDE 0160 level 1 high energy overvoltages on the line supply). The choke values are defined for a voltage drop between phases of between 3% and 5% of the nominal supply voltage. Values higher than this will cause loss of torque. These chokes should be installed upstream of the drive.

The use of line chokes is recommended in particular under the following circumstances:

- Close connection of several drives in parallel
- Line supply with significant disturbance from other equipment (interference, overvoltages)
- Line supply with voltage imbalance between phases above 1.8% of the nominal voltage
- Drive supplied by a line with very low impedance (in the vicinity of a power transformer 10 times more powerful than the drive rating)
- Installation of a large number of frequency inverters on the same line
- Reducing overloads on the cosφ correction capacitors, if the installation includes a power factor correction unit.

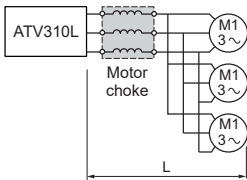

Motor chokes and LR filter cell

Motor chokes are required:

- When connecting more than 2 motors in parallel
- When the motor cable length (L), including tap-offs, is:
 - 25 m/82.2 ft maximum for a shielded motor cable (1),
 - 50 m/164.4 ft maximum for an unshielded motor cable (1).

LR filter cell comprises 3 high-frequency chokes and 3 resistors.

References

Line chokes

For drives

| | Line current without choke | | Line current with choke | | Choke Reference | Weight |
|--------------|----------------------------|-------|-------------------------|-------|-----------------|-----------------|
| | 380 V | 460 V | 380 V | 460 V | | |
| | A | A | A | A | kg/lb | |
| ATV310L075N4 | 3.5 | 3.1 | 1.9 | 1.7 | VW3A4551 | 1.500/ 3.310 |
| ATV310LU15N4 | 6.5 | 5.4 | 3.5 | 2.9 | VW3A4552 | 3.700/ 8.160 |
| ATV310LU22N4 | 8.8 | 7.2 | 5.1 | 4.4 | | |
| ATV310LU30N4 | 11.1 | 9.2 | 6.6 | 5.6 | | |
| ATV310LU40N4 | 13.7 | 11.4 | 8.5 | 7.1 | VW3A4553 | 4.100/ 9.040 |
| ATV310LU55N4 | 21.3 | 14.3 | 11.6 | 9.9 | | |

LR filter cell

For drives

| | Losses W | Nominal current A | Reference | Weight |
|-----------------------|----------|-------------------|-----------|------------------|
| | | | | kg/lb |
| ATV310L075N4...LU55N4 | 150 | 10 | VW3A58451 | 7.400/ 16.310 |

Dimensions (overall)

Line chokes, LR filter cell

| | W x H x D | |
|-----------------|-------------------|---------------------|
| | mm | in. |
| VW3A4551 | 100 x 135 x 60 | 3.94 x 5.31 x 2.36 |
| VW3A4552, A4553 | 130 x 155 x 90 | 5.12 x 6.1 x 3.54 |
| VW3A58451 | 169.5 x 340 x 123 | 6.67 x 13.39 x 4.84 |

(1) Motor cable length given for a switching frequency of 4 kHz.

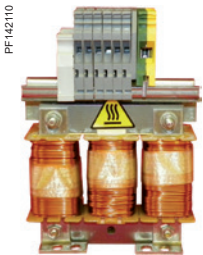

VW3A4551

Variable speed drives

Altivar 310L

Options: braking resistors, spare parts

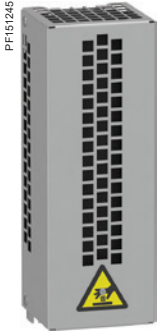

VW3A7730

| Braking resistors | | | | | |
|-------------------|---------------------|----------------------------|-------------------------------------|-----------|--------|
| For drives | Minimum Ohmic value | Ohmic value at 20° C/68 °F | Power available at 50° C/122 °F (1) | Reference | Weight |
| | Ω | Ω | | | kg/lb |

| Not protected resistor (IP 00) (2) | | | | | |
|------------------------------------|----|-----|-----|----------|-------------|
| ATV310LU15N4 | 80 | 100 | 28 | VW3A7723 | 0.600/1.320 |
| ATV310LU22N4 | 60 | | | | |
| ATV310LU30N4 | 36 | 100 | 35 | VW3A7725 | 0.850/1.870 |
| ATV310LU40N4 | 36 | | | | |
| Protected resistor (IP 20) | | | | | |
| ATV310LU075N4 | 36 | 100 | 100 | VW3A7730 | 1.500/3.306 |
| ATV310LU15N4 | 36 | | | | |
| ATV310LU22N4 | 36 | | | | |
| ATV310LU30N4 | 36 | | | | |
| ATV310LU40N4 | 36 | | | | |
| ATV310LU55N4 | 28 | 60 | 160 | VW3A7731 | 2.000/4.409 |

| For drives | Ohmic value | Average power available at 50 °C/122 °F | Length of connection cable | Reference | Weight |
|------------|-------------|---|----------------------------|-----------|--------|
| | Ω | W | m/ft | | kg/lb |

| Protected resistor (IP 65) | | | | | |
|----------------------------|-----|-----|-----------|-------------|-------------|
| ATV310LU075N4 | 100 | 100 | 0.75/2.46 | VW3A7608R07 | 0.410/0.902 |
| ATV310LU15N4 | | | | | |
| ATV310LU22N4 | | | | | |
| ATV310LU30N4 | | | | | |
| ATV310LU40N4 | | | | | |
| ATV310LU55N4 | | | | | |

| Protected resistor (IP 65) | | | | | |
|----------------------------|-----|-----|-----------|-------------|-------------|
| ATV310LU075N4 | 100 | 100 | 3.00/9.84 | VW3A7608R30 | 0.760/1.672 |
| ATV310LU15N4 | | | | | |
| ATV310LU22N4 | | | | | |
| ATV310LU30N4 | | | | | |
| ATV310LU40N4 | | | | | |
| ATV310LU55N4 | | | | | |

| Other option | | | |
|------------------|--------------|-----------|--------------|
| Description | For Drives | Reference | Weight kg/lb |
| IP54 PA/PB cover | ATV310L●●●N4 | VW3L7000 | 0.170/0.374 |

| Dimensions (overall) | | | |
|----------------------|-----------------|--|---------------------|
| Braking resistors | W x H x D | | in. |
| | mm | | |
| VW3A7608R07 | 60 x 170 x 30 | | 2.36 x 6.69 x 1.18 |
| VW3A7608R30 | 62 x 212 x 36 | | 2.44 x 8.35 x 1.42 |
| VW3A7723 | 60 x 30 x 170 | | 2.36 x 1.18 x 6.69 |
| VW3A7725 | 62 x 36 x 195 | | 2.44 x 1.42 x 7.68 |
| VW3A7730 | 105 x 295 x 100 | | 4.13 x 11.61 x 3.93 |
| VW3A7731 | 105 x 345 x 100 | | 4.13 x 13.58 x 3.93 |

Note: Braking resistors allow ATV310L drives to operate while braking to a standstill or during slowdown braking, by dissipating the braking energy. They enable maximum transient braking torque. Depending on the drive rating, the following types of resistor are available:

- Enclosed model (IP 20 casing) designed to comply with the EMC standard and protected by a temperature controlled switch
- Enclosed model (IP 65 casing) with cordset

(1) Load factor for resistors: the value of the average power that can be dissipated at 50 °C from the resistor into the casing is determined for a load factor during braking that corresponds to the majority of normal applications.

For VW3A7701...703:

- 2 s braking with a 0.6 Tn braking torque for a 40 s cycle
- 0.8 s braking with a 1.5 Tn braking torque for a 40 s cycle

(2) For not protected resistors, add a thermal overload device.

Applications

The proposed combinations can:

- Protect people and equipment (when a short-circuit occurs)
- Maintain protection upstream of the drive in the event of a short-circuit on the power stage

Two types of combination are possible:

- Drive + circuit-breaker: Minimum combination
- Drive + circuit-breaker + contactor: Minimum combination with contactor when a control circuit is needed

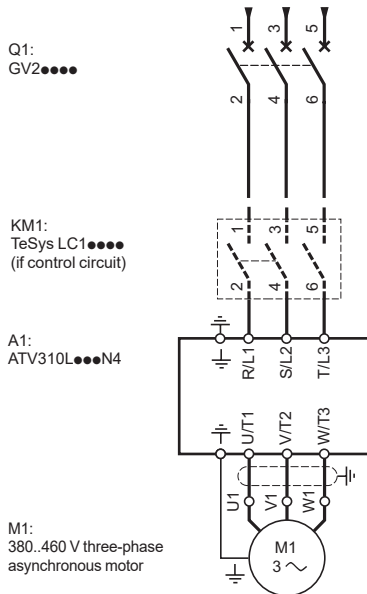

Motor starter with three-phase power supply

Motor starters

| Standard power ratings of three-phase 4-pole 50/60 Hz motors (2) | Variable speed drive | Combination with control circuit (circuit-breaker + contactor) | | TeSys contactor (1) | |
|--|----------------------|--|---------------------------|---------------------|--------|
| | | Minimum combination (circuit-breaker only) | Operating range or rating | | |
| kW | HP | A1 | Q1 | A | KM1 |
| Three-phase supply voltage: 380...460 V 50/60 Hz (4) | | | | | |
| 0.75 | 1 | ATV310L075N4 | GV2P08 GV2L08 | 4 4 | LC1D09 |
| 1.5 | 2 | ATV310LU15N4 | GV2P14 GV2L14 | 10 10 | LC1D09 |
| 2.2 | 3 | ATV310LU22N4 | GV2P14 GV2L14 | 10 10 | LC1D09 |
| 3 | 4 | ATV310LU30N4 | GV2P16 GV2L16 | 14 14 | LC1D09 |
| 4 | 5.4 | ATV310LU40N4 | GV2P16 GV2L16 | 14 14 | LC1D09 |
| 5.5 | 7.4 | ATV310LU55N4 | GV2P22 GV2L22 | 25 25 | LC1D09 |

(1) For a complete list of references for TeSys contactors, please visit our local website.

(2) Motor power indicated for combination with an ATV310L●●●N4 drive with the same rating.

(3) TeSys motor circuit-breakers:

- GV2 P●●: Thermal magnetic motor circuit-breakers with pushbutton control
- GV2 L●●: Magnetic motor circuit-breakers with control by rotary knob.

| A | |
|--------------|---|
| ATV310L075N4 | 5 |
| ATV310LU15N4 | 5 |
| ATV310LU22N4 | 5 |
| ATV310LU30N4 | 5 |
| ATV310LU40N4 | 5 |
| ATV310LU55N4 | 5 |

| V | |
|-------------|---|
| VW3A4551 | 7 |
| VW3A4552 | 7 |
| VW3A4553 | 7 |
| VW3A58451 | 7 |
| VW3A7608R07 | 8 |
| VW3A7608R30 | 8 |
| VW3A7723 | 8 |
| VW3A7725 | 8 |
| VW3A7730 | 8 |
| VW3A7731 | 8 |
| VW3A8120 | 6 |
| VW3A8121 | 6 |
| VW3L7000 | 8 |



www.schneider-electric.com

Schneider Electric Industries SAS

Head Office
35, rue Joseph Monier
F-92500 Rueil-Malmaison
France

The information provided in this documentation contains general descriptions and/or technical characteristics of the performance of the products contained herein. This documentation is not intended as a substitute for and is not to be used for determining suitability or reliability of these products for specific user applications. It is the duty of any such user or integrator to perform the appropriate and complete risk analysis, evaluation and testing of the products with respect to the relevant specific application or use thereof. Neither Schneider Electric nor any of its affiliates or subsidiaries shall be responsible or liable for misuse of the information contained herein.

Design: Schneider Electric
Photos: Schneider Electric