

## Diameter ø50mm Shaft type Incremental Rotary Encoder

Line-up

### ■ Features

- 12-24VDC power supply of line driver output(Line-up)
- Suitable for measuring angle, position, revolution, speed, acceleration and distance
- Power supply : 5VDC, 12-24VDC ±5%

### ■ Applications

- Various tooling machinery, packing machine and general industrial machinery etc.



**⚠ Please read "Caution for your safety" in operation manual before using.**



### ■ Ordering information (Former name : ENB)

<b>E50S</b>	<b>8</b>	<b>8000</b>	<b>3</b>	<b>N</b>	<b>24</b>	
Series	Shaft diameter	Pulse/1Revolution	Output phase	Output	Power supply	Cable
Diameter ø50mm, shaft type	ø8mm	Refer to resolution	2: A, B 3: A, B, Z 4: A, $\bar{A}$ , B, $\bar{B}$ 6: A, $\bar{A}$ , B, $\bar{B}$ , Z, $\bar{Z}$	T: Totem pole output N: NPN open collector output V: Voltage output L: Line driver output	5 :5VDC ±5% 24:12-24VDC ±5%	No mark: Cable type C: Connector cable type(※) CR: Axial connector type CS: Radial connector type

※Standard : E50S8-PULSE-3-N-24

※Cable length: 250mm

### ■ Specifications

Item	Diameter ø50mm shaft type of incremental rotary encoder		
Resolution(P/R) <sup>※1</sup>	*1, *2, *5, 10, 12, 15, 20, 23, 25, 30, 35, 40, 45, 50, 60, 75, 100, 120, 125, 150, 192, 200, 240, 250, 256, 300, 360, 400, 500, 512, 600, 800, 1000, 1024, 1200, 1500, 1800, 2000, 2048, 2500, 3000, 3600, 5000, 6000, 8000		
Electrical specification	Output phase	A, B, Z phase(Line driver : A, $\bar{A}$ , B, $\bar{B}$ , Z, $\bar{Z}$ phase)	
	Phase difference of output	Phase difference between A and B : $\frac{T}{4} \pm \frac{T}{8}$ (T=1cycle of A phase)	
	Control output	Totem pole output	• Low - Load current:Max. 30mA, Residual voltage : Max. 0.4VDC • High - Load current: Max. 10mA, Output voltage(Power voltage 5VDC): Min. (Power voltage-2.0)VDC, Output voltage(Power voltage 12-24VDC):Min. (Power voltage-3.0)VDC
		NPN open collector output	Load current : Max. 30mA, Residual voltage : Max. 0.4VDC
		Voltage output	Load current : Max. 10mA, Residual voltage : Max. 0.4VDC
	Response time (Rise/Fall)	Line driver output	• Low - Load current : Max. 20mA, Residual : Max. 0.5VDC • High - Load current : Max. -20mA, Output voltage(Power voltage 5VDC) : Min. 2.5VDC, Output voltage(Power voltage 12-24VDC) : Min. (Power voltage-3.0)VDC
		Totem pole output	Max. 1μs
		NPN open collector output	
		Voltage output	Max. 0.5μs
		Line driver output	
	Max. Response frequency	300kHz	
	Power supply	• 5VDC ±5%(Ripple P-P : Max. 5%) • 12-24VDC ±5%(Ripple P-P : Max. 5%)	
	Current consumption	Max. 80mA(disconnection of the load), Line driver output : Max. 50mA(disconnection of the load)	
	Insulation resistance	Min. 100MΩ(at 500VDC megger between all terminals and case)	
	Dielectric strength	750VAC 50/60Hz for 1 minute(Between all terminals and case)	
	Connection	Cable type, 250mm connector cable type, Connector type(Axial, Radial)	
Mechanical specification	Starting torque	Max. 70gf·cm(0.007N·m) <sup>※2</sup> / Max. 800gf·cm(0.08N·m) <sup>※3</sup>	
	Moment of inertia	Max. 80g·cm <sup>2</sup> (8×10 <sup>-6</sup> kg·m <sup>2</sup> ) <sup>※2</sup> / Max. 400g·cm <sup>2</sup> (4×10 <sup>-5</sup> kg·m <sup>2</sup> ) <sup>※3</sup>	
	Shaft loading	Radial : 10kgf, Thrust : 2.5kgf	
	Max. allowable revolution <sup>※4</sup>	5000rpm	
Vibration	1.5mm amplitude or 300m/s <sup>2</sup> at frequency of 10 to 55Hz(for 1 min.) in each of X, Y, Z directions for 2 hours		
Shock	Approx. Max. 75G		
Environment	Ambient temperature	-10 to 70°C, storage : -25 to 85°C	
	Ambient humidity	35 to 85%RH, storage : 35 to 90%RH	
Protection	Cable type, Connector cable type: IP50(IEC standard) <sup>※5</sup> , Connector type: IP65(IEC standard)		
Cable	ø5, 5-wire, Length : 2m, Shield cable(Line driver output : ø5, 8-wire) (AWG 24, Core diameter : 0.08mm, Number of cores : 40, Insulator out diameter : ø1)		
Accessory	ø8mm coupling, bracket		
Approval	Cable type  (Except for line driver output)		
Unit weight	Approx. 275g, Connector type : 180g		

※1: \*\* pulse is only for A, B phase(Line driver output is for A,  $\bar{A}$ , B,  $\bar{B}$  phase).      ※2: This value is for Cable type, Connector cable type(Protection: IP50).

※3: This value is for Cable type, Connector cable type(Protection: IP64)/Connector type (Protection: IP65)

※4: Make sure that max. response revolution should be lower than or equal to max. allowable revolution when selecting the resolution.

$$\text{【Max. response resolution(rpm) = } \frac{\text{Max. response frequency}}{\text{Resolution}} \times 60 \text{ sec】}$$

※5: 'Cable type, Connector cable type is option as IP64 protection.  
※Environment resistance is rated at no freezing or condensation.

## Control output diagram

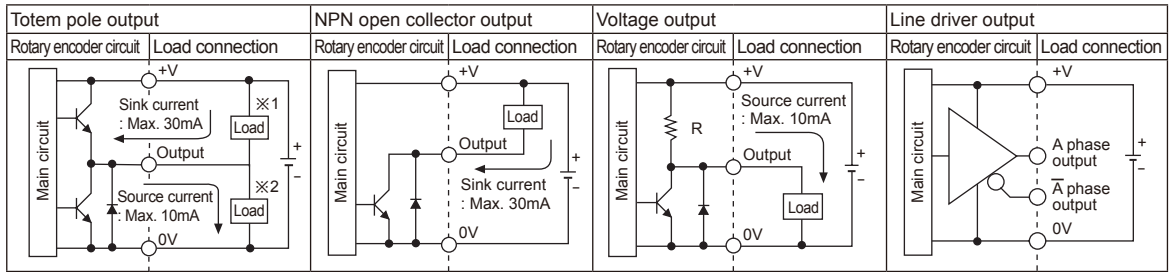

- Totem pole output type can be used for NPN open collector output type(※1) or Voltage output type(※2).
- The output circuit of A, B, Z phase are the same. (Line driver output is A,  $\bar{A}$ , B,  $\bar{B}$ , Z,  $\bar{Z}$ )

## Output waveform

- Totem pole output / NPN open collector output / Voltage output

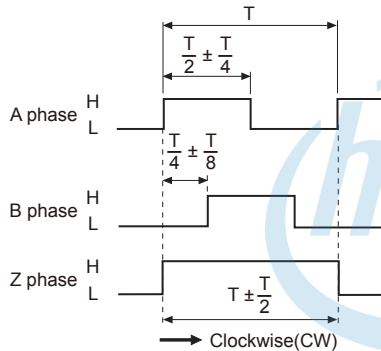

- Line driver output

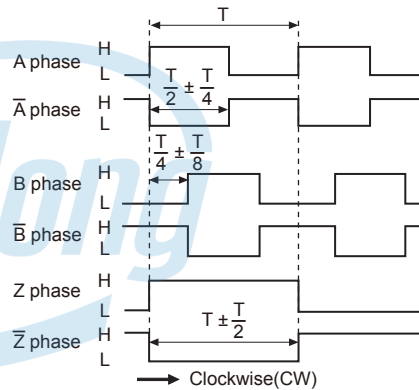

※CW : Right turn as from the shaft

## Connections

### ◎ Cable type

- Totem pole output / NPN open collector output / Voltage output

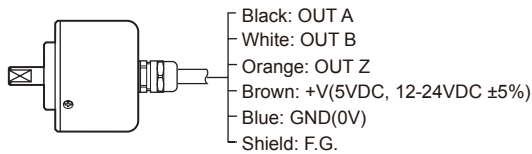

- Line driver output

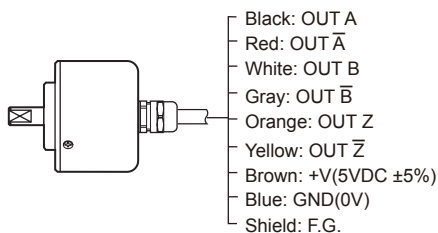

- ※Unused wires must be insulated.
- ※The shield cable and metal case of encoder must be grounded(F.G.)

## INDUSTRIAL AUTOMATION

### ◎ Cable connector type / Connector type

- Totem pole output / NPN open collector output / Voltage output
- Line driver output

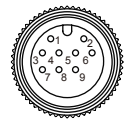

Totem pole output/ NPN open collector output/ Voltage output			Line driver output		
Pin No	Function	Cable color	Pin No	Function	Cable color
①	OUT A	Black	①	OUT A	Black
②	OUT B	White	②	OUT A-bar	Red
③	OUT Z	Orange	③	+V	Brown
④	+V	Brown	④	GND	Blue
⑤	GND	Blue	⑤	OUT B	White
⑥	F.G.	Shield	⑥	OUT B-bar	Gray
			⑦	OUT Z	Orange
			⑧	OUT Z-bar	Yellow
			⑨	F.G.	Shield

※F.G.(Field Ground) : It must be grounded separately.

(A) Photo electric sensor

(B) Fiber optic sensor

(C) Door/Area sensor

(D) Proximity sensor

(E) Pressure sensor

(F) Rotary encoder

(G) Connector/ Socket

(H) Temp. controller

(I) SSR/ Power controller

(J) Counter

(K) Timer

(L) Panel meter

(M) Tacho/ Speed/ Pulse meter

(N) Display unit

(O) Sensor controller

(P) Switching mode power supply

(Q) Stepper motor& Driver&Controller

(R) Graphic/ Logic panel

(S) Field network device

(T) Software

(U) Other

## ■ Dimensions

(unit: mm)

### ◎ Cable type, Connector cable type(Protection : IP50)

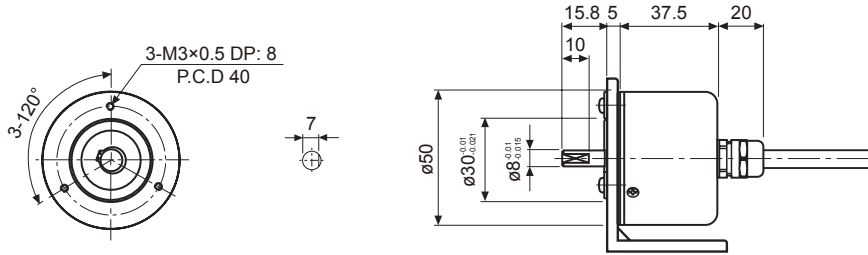

### ◎ Cable type, Connector cable type(Protection : IP64)

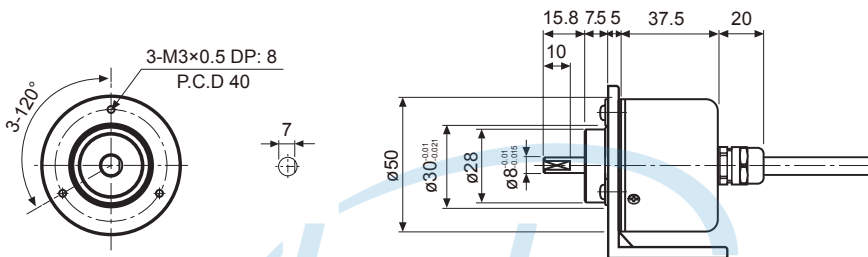

Cable for Cable type	Cable for Connector cable type
ø5, 5-wire(Line driver output: 8-wire), Length: 2000mm, Shield cable	ø5, 5-wire(Line driver output: 8-wire), Length: 250mm, Shield cable

※Connector cable is sold separately and refer to the G-10 for specifications.

### ◎ Axial / Radial connector type(Protection: IP65)

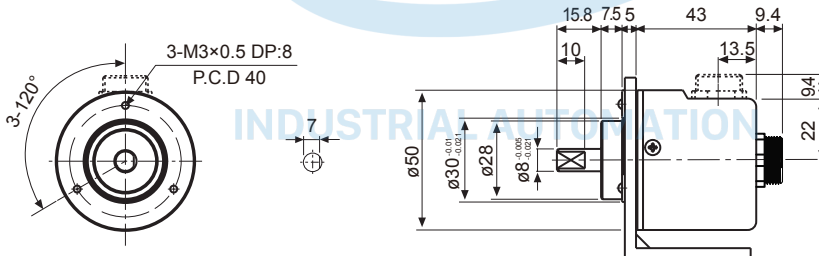

### ● Bracket

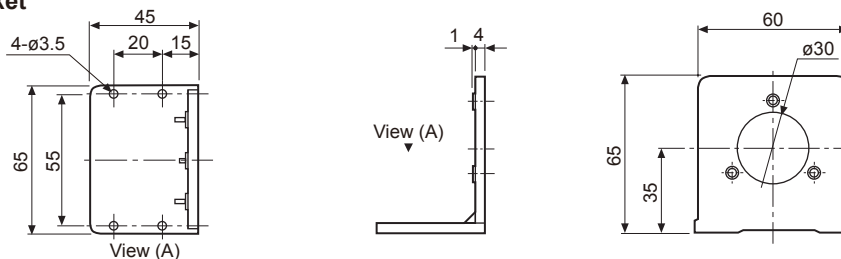

### ● Coupling(E50S)

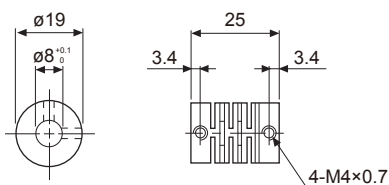

- Parallel misalignment: Max. 0.25mm
- Angular misalignment: Max. 5°
- End-play: Max. 0.2mm

※For parallel misalignment, angular misalignment, end-play terms, refer to the F-78 page.

※For flexible coupling(ERB Series) information, refer to the F-71 page.