

CJ-series Controller Link Units

CJ1W-CLK

CSM_CJ1W-CLK_DS_E_6_1

New Controller Link Units, Now with 4,000 Send Words

- The Controller Link is an FA network that can send and receive large amounts of data easily and at high speed. The Controller Link supports data links that enable sharing data between PLCs and computers and a message service that enables sending and receiving data whenever required.
- Systems can be flexibly built by using Repeater Units to enable T-branches, long-distance wiring, and converting part of the network to optical cable.



CJ1W-CLK23

Features

- Large-capacity data links are easily achieved without programming simply by setting data link tables.
- Up to 20,000 *1 send/receive words can be set per node for Units (up to 62,000 words for Boards).
- Data links can be performed with up to 4,000 *2 words per node while ensuring data concurrency.
- User-set data link tables can be changed while data links are operating. *3
- Errors for the entire system can be monitored by using error diagnosis support software and a variety of status flags.

*1. Supported for unit version 1.2 or later.

*2. CJ1W-CLK23 and 3G8F7-CLK□3 are supported.

*3. Supported for CJ1W-CLK23, 3G8F7-CLK□3, and models ending with "-V1".

System Configuration

Wired Controller Link Units

Basic Wiring (Daisy Chain Connection)

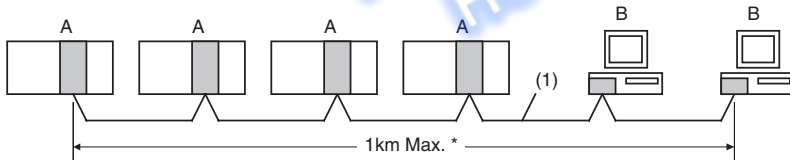

Long-distance Wiring

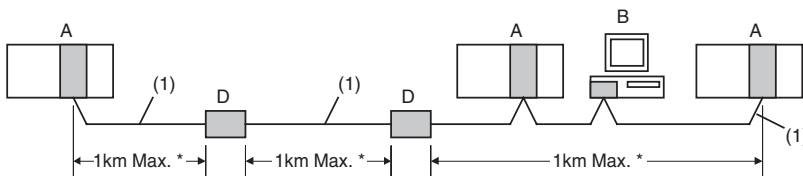

A: Wired Controller Link Unit
 B: Wired Controller Link Support Board
 C: Wire-to-Optical Repeater Unit
 D: Wire-to-Wire Repeater Unit

(1): Twisted-pair cable
 (2): Optical cable

* At 500 kbits/s

T-Branch Wiring, Partial Conversion to Optical Cable

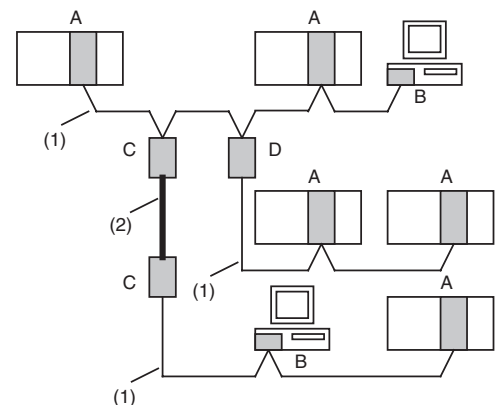

Ordering Information

International Standards

- The standards are abbreviated as follows: U: UL, U1: UL (Class I Division 2 Products for Hazardous Locations), C: CSA, UC: cULus, UC1: cULus (Class I Division 2 Products for Hazardous Locations), CU: cUL, N: NK, L: Lloyd, and CE: EC Directives.
- Contact your OMRON representative for further details and applicable conditions for these standards.

Controller Link Units

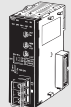
Unit classification	Product name	Specifications				No. of unit numbers allocated	Current consumption (A)		Model	Standards
		Communications cable	Communications type	Duplex support	Max. Units mountable per CPU Unit		5 V DC	24 V DC		
CJ1 CPU Bus Unit	Controller Link Unit 	Wired shielded twisted-pair cable *	Data links and message service	No	8	1	0.35	–	CJ1W-CLK23	UC1,N,L, CE

Note: This unit cannot be used with the Machine Automation Controller NJ-series.

* Use the following special cable for shielded, twisted-pair cable.

- ESVC0.5×2C-13262 (Bando Electric Wire: Japanese Company)
- ESNC0.5×2C-99-087B (Nihon Electric Wire & Cable Corporation: Japanese Company)
- ESPC 1P×0.5mm² (Nagaoka Electric Wire Co.,Ltd.: Japanese Company)
- Li2Y-FCY2×0.56qmm (Kromberg & Schubert, Komtec Department: German Company)
- 1×2×AWG-20PE+Tr.CUSN+PVC (Draka Cables Industrial: Spanish Company)
- #9207 (Belden: US Company)

Accessories

There is no accessory for the CJ series Controller Link Unit.

Controller Link Support Boards

Product name	Specifications		Accessories	Model	Standards
	Communications cable	Communications type			
Controller Link Support Board for PCI Bus 	Wired shielded twisted-pair cable	Data links and message service	<ul style="list-style-type: none"> CD-ROM ×1 * INSTALLATION GUIDE (W467) ×1 Communications connector ×1 	3G8F7-CLK23-E	CE

* The CD-ROM contains the following software.

- Controller Link (PCI) Driver
- FinsGateway Version 2003 (PCI-CLK Edition)
- FinsGateway Version 3 (PCI-CLK Edition)
- Setup Diagnostic Utility
- C Library

Repeater Units

Name	Specifications	Model	Standards
Controller Link Repeater Unit 	Wire-to-Wire Model	CS1W-RPT01	UC1,CE
	Wire-to-Optical (H-PCF) Model *1	CS1W-RPT02	
	Wire-to-Optical (GI) Model *2	CS1W-RPT03	

Using Repeater Units enables T-branches and long-distance wiring for Wired Controller Link networks, 62-node configurations, and converting part of the network to optical cable.

*1. When using wire-to-optical (H-PCF) cable, use a H-PCF cable (for both Controller Link and SYSMAC LINK) or a H-PCF optical fiber cable with connector.



*2. When using wire-to-optical (GI) cable, use a GI optical cable (for Controller Link).

Relay Terminal Block

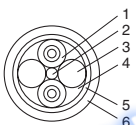

Name	Specifications	Model	Standards
Relay Terminal Block for Wired Controller Link Units 	Used for Wired Controller Link Units (set of 5)	CJ1W-TB101	-

Controller Link Units can be replaced without stopping the communications of the entire network if a Relay Terminal Block is installed in advance on the Unit in a Wired Controller Link network. Relay Terminal Blocks cannot be used on Controller Link Support Boards.

H-PCF Cables and Optical Connectors

Name	Application/construction	Specifications	Model	Standards
Optical Fiber Cables	Controller Link, SYSMAC LINK, SYSBUS  1. Optical fiber single-core cord 2. Tension member (plastic-sheathed wire) 3. Filler (plastic) 4. Filler surrounding signal wires (plastic, yarn, or fiber) 5. Holding tape (plastic) 6. Heat-resistant PV sheath	Black 10 m	S3200-HCCB101	-
		Black 50 m	S3200-HCCB501	
		Black 100 m	S3200-HCCB102	
		Black 500 m	S3200-HCCB502	
		Black 1000 m	S3200-HCCB103	
		Orange 10 m	S3200-HCCO101	
		Orange 50 m	S3200-HCCO501	
		Orange 100 m	S3200-HCCO102	
		Orange 500 m	S3200-HCCO502	
		Orange 1000 m	S3200-HCCO103	
Optical Connectors (Crimp-cut)	  CS1W-RPT02	Half lock	S3200-COCF2571	-
		Full lock	S3200-COCF2071	

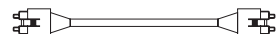
H-PCF Optical Fiber Cables with Connectors (Black Composite Cables with Two-Optical Lines and Two Power Supply Lines)

Application	Appearance	Model	Standards
Controller Link, SYSMAC LINK		S3200-CN□□□□-20-20	-
		S3200-CN□□□□-20-25	
		S3200-CN□□□□-25-25	

Optical connectors for H-PCF Optical Cables with Connectors are adhesive polished.

• Cable Length



The following cable lengths are available: 2 m, 5 m, 15 m, 20 m. For lengths of 21 m or more, contact your OMRON sales representative.

• Model Numbers

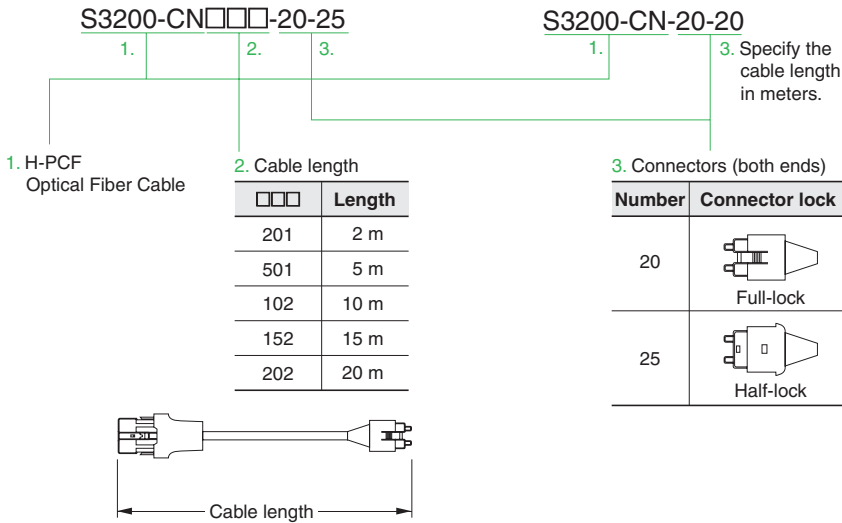
(1) 2 m, 5 m, 10 m, 15 m, or 20 m (2) 21 m or longer

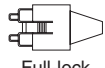

□□□	Length
201	2 m
501	5 m
102	10 m
152	15 m
202	20 m

Number	Connector lock
20	 Full-lock
25	 Half-lock

• Optical Connector Assembly Tool

Name	Applicable Unit	Model	Manufacturer	Standards
Optical Fiber Assembly Tool *	This tool is used on site for mounting crimp-cut connectors and hard plastic-clad silica optical fiber for optical transmission systems of C-series SYSBUS, SYSMAC LINK, and Controller Link.	CAK-0057	Sumitomo Electric Industries, Ltd.	-

* There is a risk of quality problems when using cables assembled by typical users, so we recommend purchasing cables with preattached connectors or having a qualified technician assemble the cables.

GI Optical Cables

A qualified technician must select, assemble, and install GI Optical Fiber Cable, so always let an optical cable specialist handle the GI cable.

Usable Optical Cables and Optical Connectors

- Optical fiber types: Graded, indexed, multi-mode, all quartz glass, fiber (GI-type AGF cable)
- Optical fiber construction (core diameter/clad diameter): 62.5/125 μm or 50/125 μm
- Optical fiber optical characteristics of optical fiber: Refer to the tables.
- Optical connector: ST connector (IEC-874-10)

• 50/125 μm AGF Cable

Item	Minimum	Standard	Maximum	Conditions
Numerical Aperture (N.A)	-	0.21	-	-
Transmission loss (dB)	-	-	3.0Lf	0.5 km ≤ Lf
			3.0Lf+0.2	0.2 km ≤ Lf ≤ 0.5 km
			3.0Lf+0.4	Lf ≤ 0.2 km
Connection loss (dB)	-	-	1.0	λ = 0.8 μm, one location
Transmission bandwidth (MHz-km)	500	-	-	λ = 0.85 μm (LD)

Lf is fiber length in km, Ta is ambient temperature, and λ is the peak wavelength of the test light source.

• 62.5/125 μm AGF Cable

Item	Minimum	Standard	Maximum	Conditions
Numerical Aperture (N.A)	-	0.28	-	-
Transmission loss (dB)	-	-	3.5Lf	0.5 km ≤ Lf
			3.5Lf+0.2	0.2 km ≤ Lf ≤ 0.5 km
			3.5Lf+0.4	Lf ≤ 0.2 km
Connection loss (dB)	-	-	1.0	λ = 0.8 μm, one location
Transmission bandwidth (MHz-km)	200	-	-	λ = 0.85 μm (LD)

Lf is fiber length in km, Ta is ambient temperature, and λ is the peak wavelength of the test light source.

Mountable Racks

Model		NJ system		CJ1 system		CP1H system	NSJ system	
		CPU Rack	Expansion Rack	CPU Rack	Expansion Backplane	CP1H PLC	NSJ Controller	Expansion Backplane
CJ1W-CLK23	Unit version 2.0	Not supported		8 Units (per CPU Unit)		2 Units *2	Not supported *3	8 Units *4
CJ1W-CLK21-V1 *1	Unit version 1.2							

*1. Discontinuation models in July 2012.

*2. A CP1W-EXT01 CJ Unit Adaptor is required.

*3. One NSJW-CLK21-V1 can be mounted to the NSJ Controller.

*4. If an Expansion Rack is used, the NSJW-CLK21-V1 cannot be mounted to the NSJ Controller.

Communications Specifications

Items	Specifications
Model	CJ1W-CLK23 3G8F7-CLK23-E CJ1W-CLK21-V1 *1 3G8F7-CLK21-EV1 *1
Type	Wired (shielded twisted-pair cable)
Communications method	N:N token-bus method
Code	Manchester code
Modulation	Baseband code
Synchronization	Flag synchronization (conforms to HDLC frames)
Transmission path format	Multidrop method (bus type)
Transmission speed	The following are the maximum transmission distances depending on the transmission speed.
Maximum transmission distance	2 Mbits/s: 500 m 1 Mbits/s: 800 m 500 kbits/s: 1 km
Maximum distance between nodes	Not specified. (Maximum transmission distance must be satisfied for the entire system.)
Medium	Specified shielded twist-pair cable Two signal wires, one shield
Node connection method	PLC: Connection to terminal block Computer: Connection using special (supplied) connector
Maximum number of nodes	32 or 62 nodes *2 *3
Applicable Programming Devices	CX-Integrator in CX-One, CX-Net in CX-Programmer *3, and Programming Console
Communications functions	Data links and message service
Number of data link words	Send words per node: 4,000 words max. (CJ1W-CLK□3), 1,000 words max. (All other Units) Number of send/receive words per node: 12,000 words max. (Pre-Ver. 1.2) 20,000 words max. (unit Ver. 1.2 or later) Total number of send words per network: 62,000 words max.
Data link areas	PLC: Bit areas (CIO Area, Work Area, Link Area *4), Data Memory (DM), Extended DM Area (EM) Computer: FinsGateway event memory
Message length	2,012 bytes max. (including the header)
RAS functions	<ul style="list-style-type: none"> • Polling node backup function • Self-diagnosis function (hardware checking at startup) • Echoback test and broadcast test (using the FINS command) • Watchdog timer • Error log function
Error control	Manchester code check CRC check (CCITT $X^{16}+X^{12}+X^5+1$)

*1. Discontinuation models in July 2012.

*2. With wired models, the maximum number of nodes is 32 if Repeater Units are not used. A Repeater Unit is required when building a network with more than 32 nodes. If a Repeater Unit is used, be sure to use only the following Controller Link Units or Boards and set the Wired Network 62 Node Enable Bit in the DM Parameter Area software switches at all nodes.

CS1W-CLK23/CLK21-V1
CJ1W-CLK23/CLK21-V1
3G8F7-CLK23-E/CLK21-EV1

*3. CX-Net in CX-Programmer version 3.1 or earlier can be used only in a system with a maximum of 32 nodes (node address 1 to 32). If a system is to be used with a maximum of 62 nodes (node addresses 1 to 62), use CX-Net in CX-Programmer version 3.2 or higher or the CX-Integrator.

*4. CJ-series PLCs do not have a Link Area, but LR000 to LR199 are automatically converted CIO 1000 to CIO 1199.

Individual Specifications

Controller Link Units

Item	Specifications
Model	CJ1W-CLK23 CJ1W-CLK21-V1 *
Applicable PLC	All CJ-series CPU Units
Number of mountable Units	8 max.
Installation site	Install onto a CPU Backplane or Expansion Backplane (classified as a CPU Bus Unit).
Storage location of network parameters and manually set data link tables	System Bus Unit Area (in the CPU Unit parameter area).
Storage location of routing tables	CPU Unit parameter area
Weight	110 g
Current consumption: 5 V in PLC	0.35 A

* Discontinuation models in July 2012.

Controller Link Support Boards (for PCI Bus), New Models

Item	Specifications		
Model	3G8F7-CLK23-E	3G8F7-CLK13-E	3G8F7-CLK53-E
Computer-compatible models	IBM PC/AT or compatible <ul style="list-style-type: none"> CPU: Intel Celeron 400 MHz or better Main memory: 128 MB minimum One or more PCI bus slots (PCI bus revision 2.0 or later, power supply: 5 V) Free hard disk space: 70 MB min. CD-ROM drive: One required for installation Display: VGA (640 x 480 (pixels) min.) (Other conditions conform to the OS.)		
Compatible OS	<ul style="list-style-type: none"> FinsGateway Version2003 *1 <ul style="list-style-type: none"> Windows 7 (32bit) Professional Windows 7 (32bit) Home Premium Windows Vista Business Windows Vista Home Premium Windows XP Professional Windows XP Home Edition Windows 2000 Professional FinsGateway Version3 *2 <ul style="list-style-type: none"> Windows XP Professional Windows XP Home Edition Windows 2000 Professional Windows NT4.0 (Service Pack 3 or higher) Windows ME Windows 98SE 		
Weight	104 g	120 g (excluding mounting bracket)	124 g (excluding mounting bracket)
Current consumption	5 V in PLC	0.35 A	0.54 A
	External 24 V	–	0.35 A

*1. Install the software from CD Ver. 3.10 or higher if the operating system is Windows 7 (32bit) or Windows Vista.

*2. Install FinsGateway version 3 if the operating system is Windows NT 4.0 (Service pack 3 or higher), Windows ME, or Windows 98SE. In that case, however, the new functions of Controller Link Support Boards for the PCI Bus cannot be used (i.e., automatic data link creation with 1:N allocation, changing data link tables with active data links, 62-node setting for wired models, and maximum of 4000 send words).

Controller Link Support Boards (for PCI Bus), Old Models

Item	Specifications		
Model *1	3G8F7-CLK21-EV1	3G8F7-CLK12-EV1	3G8F7-CLK52-EV1
Computer-compatible models	IBM PC/AT or compatible <ul style="list-style-type: none"> CPU: Intel Celeron 400 MHz or better Main memory: 128 MB minimum One or more PCI bus slots (PCI bus revision 2.0 or later, power supply: 5 V) Free hard disk space: 70 MB min. CD-ROM drive: One required for installation Display: VGA (640 x 480 (pixels) min.) (Other conditions conform to the OS.)		
Compatible OS *2	<ul style="list-style-type: none"> FinsGateway Version2003 <ul style="list-style-type: none"> Windows XP Professional Windows XP Home Edition Windows 2000 Professional FinsGateway Version3 <ul style="list-style-type: none"> Windows XP Professional Windows XP Home Edition Windows 2000 Professional Windows NT4.0 (Service Pack 3 or higher) Windows ME Windows 98SE 		
Weight	104 g	120 g (excluding mounting bracket)	124 g (excluding mounting bracket)
Current consumption	5 V in PLC	0.35 A	0.54 A
	External 24 V	–	0.35 A

*1. Discontinuation models in July 2012.

*2. Install FinsGateway version 3 if the operating system is Windows NT 4.0 (Service pack 3 or higher), Windows ME, or Windows 98SE. In that case, however, the new functions of Controller Link Support Boards for the PCI Bus cannot be used (i.e., automatic data link creation with 1:N allocation, changing data link tables with active data links, 62-node setting for wired models, and maximum of 4000 send words).

Repeater Units

Item	Specifications		
Model	CS1W-RPT01	CS1W-RPT02	CS1W-RPT03
Supported Units/Boards	All wired Controller Link Units and Boards Note: If a maximum of 62 nodes is used, models that support 62 nodes must be used.		
Transmission line	Wire-to-wire	Wire-to-optical (H-PCF)	Wire-to-optical (GI)
Transmission line format	Multi-drop Tree	1:1 type	1:1 type
Installation	Repeater Units are not mounted to the PLC. They are mounted separately with screws or on a DIN Track.		
Weight	126 g	113 g (excluding mounting bracket)	116 g (excluding mounting bracket)
Allowable power supply voltage range	20.4 to 26.4 V DC (24 V DC -15 to 10%)		
Current consumption	24 V DC at 0.06 A		24 V DC at 0.07 A
Inrush current	2.5 A max. at 24 V DC (5 ms after startup)		

Repeater Units are used to expand the Controller Link network for wired models. For Wired-to-optical Repeater Units, always use a set of two (1:1). Optical Ring Controller Link Units and Boards cannot be connected to the optical cable section between Repeater Units.

External Interface

CJ1W-CLK23/CJ1W-CLK21-V1 *

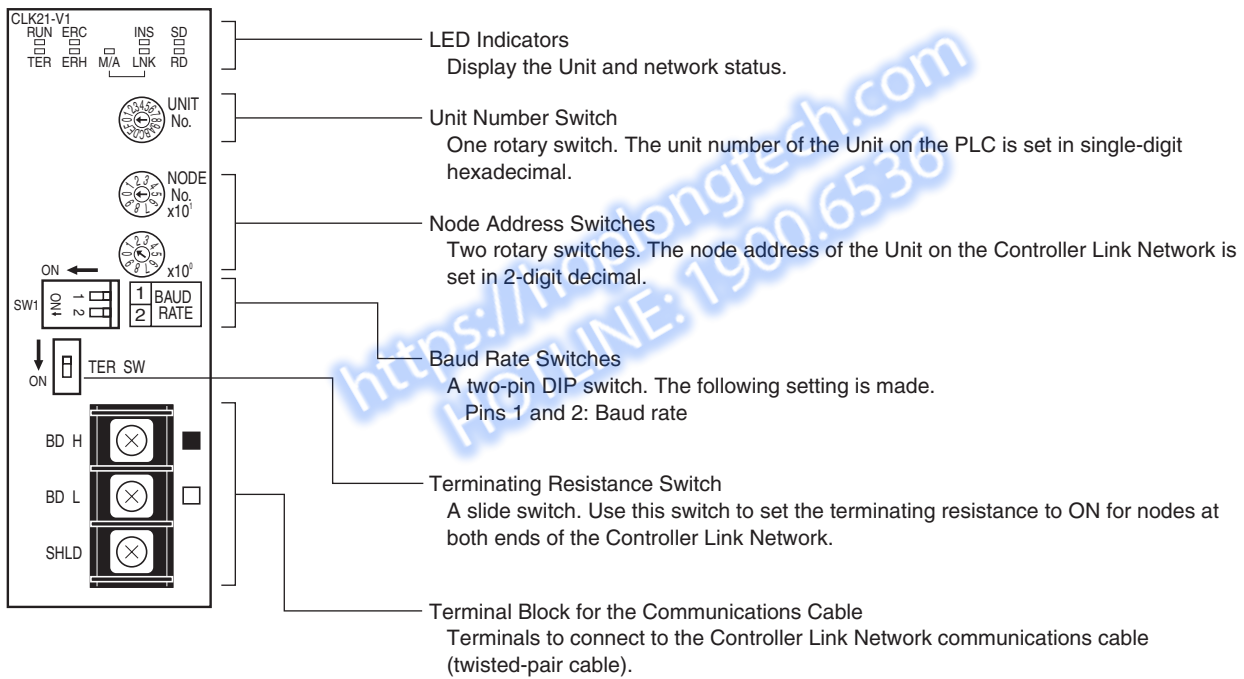

* Discontinuation models in July 2012.

Definition of Terminal Block Pin Names for Communications Cables

Marking	Notation	Signal name	Line color
■	BD H	Communication data, high	Black
□	BD L	Communication data, low	White
None	SHLD	Shield	None

Crimp Terminals

Use crimp terminals (M3) having the dimensions shown below.



Differences in Specifications of New and Old Models

Controller Link Units

Functions	CJ1W-CLK23	CJ1W-CLK21-V1 The following models are discontinued.	CJ1W-CLK21-V1 The following models are discontinued.	CJ1W-CLK21 The following models are discontinued.
	Unit version 2.0	Unit version 1.2	Pre-Ver. 1.2	Pre-Ver. 1.2
Number of data link send words (data link areas that are created for a single node in a single PLC)	20,000 max.		12,000 max.	
Number of send words per node (total of area 1 and area 2)	4,000 words max. (user-set links only)	1,000 words max.		
Data Link Area	Allocation setting can be performed for same areas in areas 1 and 2.		Allocation setting can be performed for same areas in areas 1 and 2.	
Max. Units mountable per PLC	8 Units		4 Units	
Automatic data link setting	Choose from equality layout or 1:N allocations (common type, 1:1, chain type)			Supported for equality layout only.
Changing data link allocations during active data links	Supported (Data link tables can be changed during active data links.)			Not supported.
Maximum connectable nodes	62 nodes *1			32 nodes
Mixed use	Yes *2			
Compatible support software	CX-Integrator for CX-One V2.1 or higher, or CX-Net for CX-Programmer Ver. 7.2 or higher	CX-Net for CX-Programmer Ver. 5.0 or higher	CX-Net for CX-Programmer Ver. 3.2 or higher	CX-Net for CX-Programmer Ver. 1.0 or higher

*1. For wired models, the maximum number of nodes is 32 if Repeater Units are not used.

*2. Old models and new models can be used mixed on the same network. In that case, however, build the system using the specifications for the old models. The data link send/receive words can be separately set to their maximums when new and old models are mixed.

Controller Link Support Boards (for PCI Bus)

Functions	3G8F7-CLK23-E	3G8F7-CLK21-EV1 The following models are discontinued.	3G8F7-CLK21-E The following models are discontinued.
	Number of data link send/receive words (data link areas for sending/receiving that are created for a single node in a single computer)	62,000 max.	32,000 max.
Send words per node	4,000 words max. (user-set links only)	1,000 words max.	
Changing data link allocations during active data links	Supported. (Data link tables can be changed during active data links.)		Not supported.
Maximum connectable nodes	62 nodes *1		32 nodes
Mixed use	Yes *2		
Compatible FinsGateway *3	FinsGateway Version 2003.21 or higher (In CD Ver. 3.00 or higher)	FinsGateway Version 2003.00 or higher (In CD Ver. 2.00 or higher)	FinsGateway Version 3.00 or higher (In CD Ver. 1.00 or higher)
Compatible support software	CX-Integrator for CX-One Ver. 2.1 or higher, or CX-Net for CX-Programmer Ver. 7.2 or higher	CX-Net for CX-Programmer Ver. 3.2 or higher	CX-Net for Ver. 1.0 or higher

*1. For wired models, the maximum number of nodes is 32 if repeater units are not used.

*2. Old models and new models can be used mixed on the same network. In that case, however, build the system using the specifications for the old models. The data link send/receive words can be separately set to their maximums when new and old models are mixed.

*3. FinsGateway Version 2003 is compatible with Windows 7 (32bit) (CD Ver.3.10 or higher), Windows Vista (CD Ver.3.10 or higher), Windows XP and Windows 2000. For Windows NT4.0 (Service Pack 3 or higher), Windows ME, or Windows 98SE, use FinsGateway Version3. (With FinsGateway Version 3, only functions supported by the 3G8F7-CLK21 can be used.)

Usage Precautions

- Old models and new models can be used mixed on the same network. In that case, however, build the system using the specifications for the old models. The data link send/receive words can be separately set to their maximums when new and old models are mixed.
- Repeater Units can be used to expand a Wired Controller Link Network. For Wired-to-optical Repeater Units, always use a set of two (1:1). Optical Ring Controller Link Units and Boards cannot be connected to the optical cable section between Repeater Units.
- Connect Repeater Units so that there are no more than two stages between any two nodes. One set of two Wire-to-Optical Repeater Units is counted as one stage.

Dimensions

(Unit: mm)

CJ1W- CLK23/ CJ1W- CLK21-V1 *

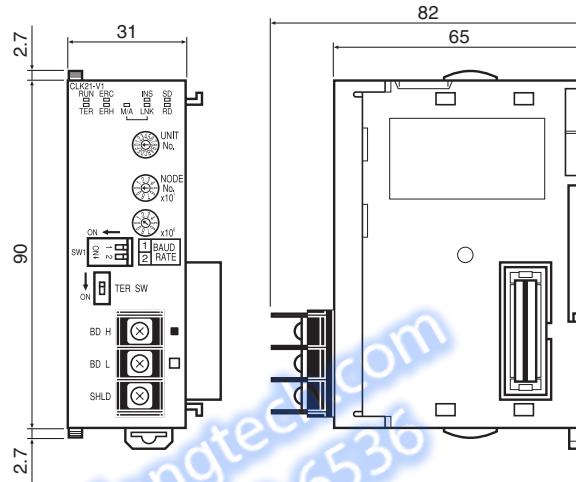

* Discontinuation models in July 2012.

Related Manuals

Cat.No	Model	Name	Applications	Description
W309	CS1W-CLK23 CS1W-CLK21-V1 CJ1W-CLK23 CJ1W-CLK21-V1 C200HW-CLK21 CVM1-CLK21 CQM1H-CLK21 CS1W-RPT01/02/03	Controller Link Units Operation Manual	Used when information regarding operating procedures for Wired Controller Link Units is needed.	Describes operating procedures for Controller Link Units. Controller Link Units can connect to Wired Controller Link Units.
W422	3G8F7-CLK12-V1 3G8F7-CLK52-V1 3G8F7-CLK21-V1	Controller Link Support Boards for PCI Bus Installation Guide (3G8F7-CLK12/21/52-V1)	Used when information regarding setup procedures for Controller Link Support Boards for PCI bus connections is needed.	Describes the setup method for the Controller Link Support Boards for PCI bus connections.
W467	3G8F7-CLK13 3G8F7-CLK12-V1 3G8F7-CLK53 3G8F7-CLK52-V1 3G8F7-CLK23 3G8F7-CLK21-V1	Controller Link Support Board for PCI Bus Installation Guide (3G8F7-CLK13/12-V1/53/52-V1/23/21-V1)	Used when information regarding setup procedures for Controller Link Support Boards for PCI bus connections is needed.	Describes the setup method for the Controller Link Support Boards for PCI bus connections.
W383	3G8F7-CLK13 3G8F7-CLK12-V1 3G8F7-CLK53 3G8F7-CLK52-V1 3G8F7-CLK23 3G8F7-CLK21-V1	Controller Link Support Boards for PCI Bus Operation Manual	Used when information regarding setup procedures for Controller Link Support Boards for PCI bus connections is needed.	Describes the setup method for the Controller Link Support Boards for PCI bus connections.
W464	CXONE-AL□□C-V□/ AL□□D-V□	CX-Integrator Operation Manual	Used when network setup or network monitoring needs to be performed.	Describes the operating procedures for the CX-Integrator.
W463	CXONE-AL□□C-V□/ AL□□D-V□	CX-One FA Integrated Tool Package Setup Manual	Used when installing software from the CX-One.	Provides an overview of the FA Integration Tool Package CX-One, and describes the CX-One installation procedures.

<https://hoplong.com>
HOTLINE: 1900.6538

Read and Understand This Catalog

Please read and understand this catalog before purchasing the products. Please consult your OMRON representative if you have any questions or comments.

Warranty and Limitations of Liability

WARRANTY

OMRON's exclusive warranty is that the products are free from defects in materials and workmanship for a period of one year (or other period if specified) from date of sale by OMRON.

OMRON MAKES NO WARRANTY OR REPRESENTATION, EXPRESS OR IMPLIED, REGARDING NON-INFRINGEMENT, MERCHANTABILITY, OR FITNESS FOR PARTICULAR PURPOSE OF THE PRODUCTS. ANY BUYER OR USER ACKNOWLEDGES THAT THE BUYER OR USER ALONE HAS DETERMINED THAT THE PRODUCTS WILL SUITABLY MEET THE REQUIREMENTS OF THEIR INTENDED USE. OMRON DISCLAIMS ALL OTHER WARRANTIES, EXPRESS OR IMPLIED.

LIMITATIONS OF LIABILITY

OMRON SHALL NOT BE RESPONSIBLE FOR SPECIAL, INDIRECT, OR CONSEQUENTIAL DAMAGES, LOSS OF PROFITS OR COMMERCIAL LOSS IN ANY WAY CONNECTED WITH THE PRODUCTS, WHETHER SUCH CLAIM IS BASED ON CONTRACT, WARRANTY, NEGLIGENCE, OR STRICT LIABILITY.

In no event shall the responsibility of OMRON for any act exceed the individual price of the product on which liability is asserted.

IN NO EVENT SHALL OMRON BE RESPONSIBLE FOR WARRANTY, REPAIR, OR OTHER CLAIMS REGARDING THE PRODUCTS UNLESS OMRON'S ANALYSIS CONFIRMS THAT THE PRODUCTS WERE PROPERLY HANDLED, STORED, INSTALLED, AND MAINTAINED AND NOT SUBJECT TO CONTAMINATION, ABUSE, MISUSE, OR INAPPROPRIATE MODIFICATION OR REPAIR.

Application Considerations

SUITABILITY FOR USE

OMRON shall not be responsible for conformity with any standards, codes, or regulations that apply to the combination of products in the customer's application or use of the products.

At the customer's request, OMRON will provide applicable third party certification documents identifying ratings and limitations of use that apply to the products. This information by itself is not sufficient for a complete determination of the suitability of the products in combination with the end product, machine, system, or other application or use.

The following are some examples of applications for which particular attention must be given. This is not intended to be an exhaustive list of all possible uses of the products, nor is it intended to imply that the uses listed may be suitable for the products:

- Outdoor use, uses involving potential chemical contamination or electrical interference, or conditions or uses not described in this catalog.
- Nuclear energy control systems, combustion systems, railroad systems, aviation systems, medical equipment, amusement machines, vehicles, safety equipment, and installations subject to separate industry or government regulations.
- Systems, machines, and equipment that could present a risk to life or property.

Please know and observe all prohibitions of use applicable to the products.

NEVER USE THE PRODUCTS FOR AN APPLICATION INVOLVING SERIOUS RISK TO LIFE OR PROPERTY WITHOUT ENSURING THAT THE SYSTEM AS A WHOLE HAS BEEN DESIGNED TO ADDRESS THE RISKS, AND THAT THE OMRON PRODUCTS ARE PROPERLY RATED AND INSTALLED FOR THE INTENDED USE WITHIN THE OVERALL EQUIPMENT OR SYSTEM.

PROGRAMMABLE PRODUCTS

OMRON shall not be responsible for the user's programming of a programmable product, or any consequence thereof.

Disclaimers

CHANGE IN SPECIFICATIONS

Product specifications and accessories may be changed at any time based on improvements and other reasons.

It is our practice to change model numbers when published ratings or features are changed, or when significant construction changes are made. However, some specifications of the products may be changed without any notice. When in doubt, special model numbers may be assigned to fix or establish key specifications for your application on your request. Please consult with your OMRON representative at any time to confirm actual specifications of purchased products.

DIMENSIONS AND WEIGHTS

Dimensions and weights are nominal and are not to be used for manufacturing purposes, even when tolerances are shown.

PERFORMANCE DATA

Performance data given in this catalog is provided as a guide for the user in determining suitability and does not constitute a warranty. It may represent the result of OMRON's test conditions, and the users must correlate it to actual application requirements. Actual performance is subject to the OMRON Warranty and Limitations of Liability.

ERRORS AND OMISSIONS

The information in this document has been carefully checked and is believed to be accurate; however, no responsibility is assumed for clerical, typographical, or proofreading errors, or omissions.

2012.7

In the interest of product improvement, specifications are subject to change without notice.

OMRON Corporation
Industrial Automation Company

<http://www.ia.omron.com/>

(c)Copyright OMRON Corporation 2012 All Right Reserved.