

# REVERSIBLE MOTORS

## INDEX

CHARACTERISTICS OF REVERSIBLE MOTOR .....	63
REVERSIBLE MOTOR 6W(□60mm) .....	66
REVERSIBLE MOTOR 15W(□70mm) .....	68
REVERSIBLE MOTOR 15W(□80mm) .....	70
REVERSIBLE MOTOR 25W(□80mm) .....	72
REVERSIBLE MOTOR 40W(□90mm) .....	74
REVERSIBLE MOTOR 60W(□90mm) .....	76
REVERSIBLE MOTOR 90W(□90mm) .....	79



# CODING SYSTEM

## MOTOR

MAKER	SIZE	MOTOR TYPE	OUTPUT	SHAFT TYPE	VOLTAGE	GEAR TYPE	SPECIAL TYPE
<b>S</b>	<b>9</b>	<b>I</b>	<b>40</b>	<b>G</b>	<b>B</b>	<b>H</b>	<b>E</b>

**S** : SPG Co., Ltd.

**SIZE**

- 6 : □60(mm)
- 7 : □70(mm)
- 8 : □80(mm)
- 9 : □90(mm)

**MOTOR TYPE**

- I : Induction Motor
- R : Reversible Motor

**OUTPUT**

03 : 3W	90 : 90W
06 : 6W	120 : 120W
15 : 15W	150 : 150W
25 : 25W	180 : 180W
40 : 40W	200 : 200W
60 : 60W	

**SHAFT TYPE**

- G : Gear Type
- S : Straight Type
- D : D-Cut Type
- K : Key Type

**VOLTAGE**

A : 1∅AC 110V	60Hz	(4Pole)
B : 1∅AC 220V	60Hz	(4Pole)
C : 1∅AC 100V	50/60Hz	(4Pole)
D : 1∅AC 200V	50/60Hz	(4Pole)
E : 1∅AC 115V	60Hz	(4Pole)
X : 1∅AC 220~240V	50Hz	(4Pole)
U : 3∅AC 200V	50/60Hz	(4Pole)
T : 3∅AC 220V	50/60Hz	(4Pole)
S : 3∅AC 380~440V	50/60Hz	(4Pole)

**GEAR TYPE**

- H : Heavy Impact
- L : Light Impact

**SPECIAL TYPE**

- E : Electro-magnetic Brake Type
- T : Terminal Box Type(Terminal Block Type)
- T1 : Terminal Box Type(PCB Type Terminal Block) (25~90W)
- T2 : Conduit Box Type(25~90W)
- B : Semi-Brake Type
- S : Variable Speed Control(Pack Type)
  - S12 : T.G Voltage 12V Type
  - S24 : T.G Voltage 24V Type
- V : Variable Speed Control(Unit Type)
  - V12 : T.G Voltage 12V Type
- ES : Electro-Magnetic Brake Variable Speed Control(Pack Type)
  - ES12 : T.G Voltage 12V Type
  - ES24 : T.G Voltage 24V Type

※ NOTE 1) 'H' & 'L' type are applied to over 40W.  
 • 'H' type is the standard for over 60W.  
 • 'L' type is the standard for over 40W.

※ NOTE 2) Key Type are applied to over □80 15W

## SPEED CONTROLLER (SR PACK TYPE)

CONTROLLER TYPE	VOLTAGE	OUTPUT
<b>SR</b>	<b>B</b>	<b>01</b>

**SR SERIES**

※ NOTE) The applicable motor is for T.G. 12V.

**CONTROLLER TYPE**

**VOLTAGE**

- A : 1∅ AC110V 60Hz (4Pole)
- B : 1∅ AC220V 60Hz (4Pole)
- C : 1∅ AC100V 50/60Hz (4Pole)
- D : 1∅ AC200V 50/60Hz (4Pole)
- E : 1∅ AC115V 60Hz (4Pole)
- X : 1∅ AC220~240V 50Hz (4Pole)

**OUTPUT**

- 01 : 6W
- 02 : 15W~90W

## SPEED CONTROLLER (SS PACK TYPE)

CONTROLLER TYPE	VOLTAGE	OUTPUT	RUN / STOP TYPE
<b>SS</b>	<b>B</b>	<b>01</b>	<b>SRSS</b>

**SS SERIES**

※ NOTE) The applicable motor is for T.G. 24V.

**CONTROLLER TYPE**

- A : 1∅ AC110V 60Hz (4Pole)
- B : 1∅ AC220V 60Hz (4Pole)
- C : 1∅ AC100V 50/60Hz (4Pole)
- D : 1∅ AC200V 50/60Hz (4Pole)
- E : 1∅ AC115V 60Hz (4Pole)
- X : 1∅ AC220V~240V 50Hz (4Pole)

**OUTPUT**

- 01 : 6W(Standard Type)
- 02 : 15W~40W(Standard Type)
- 03 : 6W~90W(High Output Type)

**RUN / STOP TYPE**

SRSS : Slow Run Slow Stop

### SPEED CONTROLLER (UNIT TYPE)

MAKER	CONTROLLER TYPE	OUTPUT	TYPE	VOLTAGE	T.G VOLTAGE
S	U	A	40	I B	- V12

V12 : T.G Voltage 12V Type

A : 1Ø AC110V	60Hz	(4Pole)
B : 1Ø AC220V	60Hz	(4Pole)
C : 1Ø AC100V	50/60Hz	(4Pole)
D : 1Ø AC200V	50/60Hz	(4Pole)
E : 1Ø AC115V	60Hz	(4Pole)
X : 1Ø AC220~240V	50Hz	(4Pole)

I : Induction Motor  
 ※ NOTE) Unit Type of Speed Controller does not have Reversible Motor.(715 Type : No marking)

06 : 6W	25 : 25W	90 : 90W
715 : 15W(□70)	40 : 40W	120 : 120W
15 : 15W(□80)	60 : 60W	180 : 180W

A : Analogue Type  
D : Digital Type

U : Unit Type

S : SPG Co.,Ltd.

### BRAKE PACK (CONTACT TYPE)

BRAKE TYPE	VOLTAGE	MOTOR TYPE
SB	B	- IR

IR : 1Ø Motor  
I : 3Ø Motor

A : 1Ø AC 110V	60Hz	(4Pole)
B : 1Ø AC 220V	60Hz	(4Pole)
C : 1Ø AC 100V	50/60Hz	(4Pole)
D : 1Ø AC 200V	50/60Hz	(4Pole)
X : 1Ø AC 220~240V	50Hz	(4Pole)
U : 3Ø AC 200V	50/60Hz	(4Pole)
T : 3Ø AC 220V	50/60Hz	(4Pole)
S : 3Ø AC 380~440V	50/60Hz	(4Pole)

SB SERIES

### GEAR HEAD

MAKER	SIZE	SHAFT TYPE	OUTPUT	GEAR RATIO	BEARING TYPE	SHAFT IMPACT TYPE	SPECIAL TYPE
S	9	K	C	36	B	H	- S

S : Flange Type

※  
H : Heavy Impact  
L : Light Impact

B : Ball bearing + Metal bearing(6W~40W)  
All Ball bearing(60W MIN)  
B1: All Ball bearing(6W~40W)  
M : Metal bearing(6W~40W)

Reduction Ratio(36:1/36)

T : 3W	C : 60W~120W
A : 6W~ 25W	D : 60W~120W
B : 40W	H : 150W~200W

S : Straight Type  
D : D-Cut Type  
K : Key Type

6 : □60(mm)
7 : □70(mm)
8 : □80(mm)
9 : □90(mm)

※ NOTE) 'H' & 'L' type are applied to over 40W.  
 • 'H' type is the standard for over 60W.  
 • 'L' type is the standard for over 40W.

S : SPG Co.,Ltd.

### BRAKE PACK (NON CONTACT TYPE)

BRAKE TYPE	VOLTAGE	SPECIAL TYPE
SB	B	- NCR

NCR : Non Contact Relay  
ENCR : Brake type Non Contact Relay

A : 1Ø AC 110V	60Hz	(4Pole)
B : 1Ø AC 220V	60Hz	(4Pole)
C : 1Ø AC 100V	50/60Hz	(4Pole)
D : 1Ø AC 200V	50/60Hz	(4Pole)
X : 1Ø AC 220V~240V	50Hz	(4Pole)

SB SERIES

# Characteristics of REVERSIBLE MOTOR

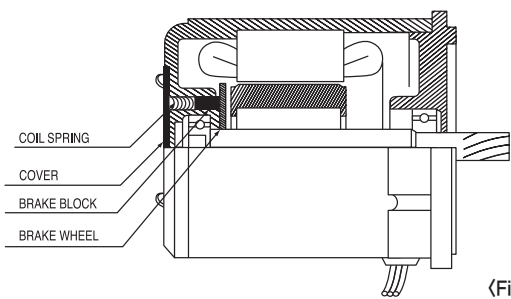

<Fig. 1>

## 1. Characteristics of REVERSIBLE MOTOR

- The reversible motor is a condenser type single phase induction motor. Thus, its general characteristics are the same as those of the induction motor.
- Frequent reverse operation is possible. The reversible motor has a temporary brake device built inside the motor to facilitate the operation in normal direction as well as reverse. Also, the main and sub coils of the stator have their windings manufactured with the same method to guarantee the identical characteristics between them (Refer to <Fig. 2>).
- Also, it has a higher starting torque to facilitate frequent changes in rotational direction from normal direction to reverse direction, and vice versa, within a short time (Refer to <Fig. 3>).
- The temporary brake is employed to prevent overrun. The temporary brake has a little retaining force to provide excellent instantaneous stop by preventing overrun when stopping (Refer to <Fig. 1>).
- The changeover switch can help the motor reverse its rotational direction easily within a short time so that it is suitable for such operation that changes the rotational direction frequently from normal to reverse, and vice versa. Therefore, this motor is called a reversible motor.
- The rated operating time is 30 minutes. Since the reversible motor is designed to be capable of controlling the directional changes in rotation, the loss input is larger and the temperature can rise higher compared with the induction motor. Hence, the rated operating time is limited to 30 minutes.
- Thus, 30 minutes of rated operating time means that the motor can have at least 30 minutes of non-stop operation within the safe upper limit of the temperature rise.
- In general, the reversible motor has the same characteristics as the induction motor in terms of number of rotations, characteristics of torque, voltage and condenser.

PHASE	SIZE	OUTPUT (W)	MODEL	HOLDING TORQUE		OVER RUN
				(g · cm)	(N · cm)	
Single phase	□60mm	6	S6R06G□	50	0.5	4
	□70mm	15	S7R15G□	130	1.3	5
	□80mm	15	S8R15G□	150	1.5	5
		25	S8R25G□	150	1.5	5
	□90mm	40	S9R40G□( )	400	4.0	6
		60	S9R60G□( )	400	4.0	6
		90	S9R90G□( )	400	4.0	6

<Table 1> HOLDING TORQUE and OVER RUN of REVERSIBLE MOTOR

## 2. BRAKE Structure

- The temporary brake of the reversible motor has characteristics as follows.
  - ① A frictional load applied to improve frequent reversal operation.
  - ② Reduces overrun.
  - ③ Provides a little holding torque.
- The reversible motor has characteristics described above due to its general use for remote controlling purpose. Thus, structurally, as shown in (Fig. 1), the brake rod is forced towards the brake wheel by a spring to make them contact each other.
- Since the brake structure described above has a limitation in terms of a frictional load, SPG adjusted the brake power to be about 10% of the motor output torque.
- The figures representing the holding torque and the overrun in <Table 1> may have more or less deviations for each motor. They may also have some discrepancies depending on the operating duration and the ambient temperature. It is advised therefore that the table figures should be used only for reference purpose.
- The rated torque, starting torque, and electric current of the reversible motor were measured in the circumstances where the temporary brake rod is installed in the motor. Therefore, there will be no problem even if the corresponding table figures are used when selecting a motor. The conservative selection of a motor is recommended, however, because the figures may have some deviation depending on the brake rod employed to the motor.
- Attention is required for a case has shown that the holding torque may fall below the figures in <Table 1> in the initial phase of operation.

CIRCUIT DIAGRAM (C.W)

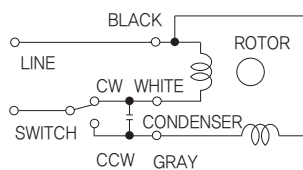

<Fig. 2>

SPEED- TORQUE CURVE

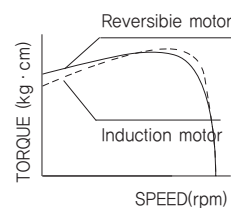

<Fig. 3>

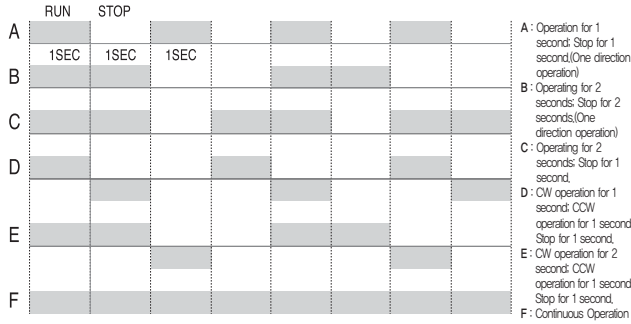

〈Fig.4〉 OPERATING CYCLE

### 3. Operating Time and Temperature Rise

- Although 30 minutes of rated operating time is specified for the reversible motor, the rated operating time may change depending on the operation conditions if the operation frequently repeats stop and run (On-Off) within a short period of time.
- If the reversible motor frequently repeats stop and run (On-Off) within a short time, the starting current increases and cause the motor temperature to rise. However, longer rated operating time may be obtained by allowing the motor to remain stop longer, because the stoppage can provide a chance of natural cooling for the motor and decrease its temperature.
- The conditions of the intermittent (On-Off) operation are determined as shown in A - F of (Fig. 4). F stands for continuous operation.
- The characteristics shown in (Fig. 5) through (Fig. 8) represent the measurements of the motor for 200V 50/60Hz. Naturally, the characteristics of the motor for 220V 60Hz will have better characteristic values than 200V 60W due to the increase of the voltage by 10%. Therefore, it is encouraged to operate the motor at a temperature below the ambient temperature.
- The temperature rise measurement is performed when the motor, under no-load, is prevented from transferring its internal heat to the outside through the motor's external contact points using thermograph. This method of measurement can provide the highest possible temperature rise.
- Especially, if either a load or an inertia load is greater than the motor's rated torque, it requires longer time to start or reverse the direction, resulting in a greater temperature rise, which requires a user's attention.
- The specified temperature rise of the reversible motor is 60°C ( $\Delta T$  value) in general, and be careful not to exceed the temperature. Also, the greater the output of the motor is, the shorter the operating time becomes.
- There is a case that the motor alone is used, but mostly the motor is used in combination with the gearhead. Hence, when the motor of S8R25GD is used with no-load in combination with the gearhead of S8KA50B, the temperature rise draws an L curve as shown in (Fig. 9) and the temperature rise becomes lower and the operating time becomes longer by about 30 minutes as compared with the motor shown in (Fig. 7).
- (Table 2) shows various heat radiation plates for mounting surface. The table indicates that the temperature decreases by about 6°C when the diameter of the heat radiation plate is

doubled, and greater heat conductivity of aluminum decelerates the temperature rise compared to that of the steel. Painting the aluminum will additionally lower the temperature by about 3°C.

- Although the principle is to keep the coil temperature below the specified temperature for the insulation class, it is possible to continue the operation if the motor housing surface temperature remains lower than 90°C. The temperature of the motor varies depending on the load, operating cycle, motor's mounting method, and ambient temperature.

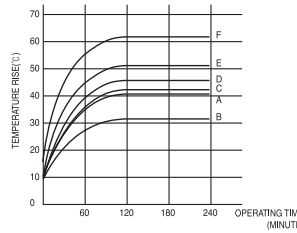

〈Fig.5〉 INTERMITTENT OPERATION OF S6R06GD(WITHOUT GEAR HEAD)

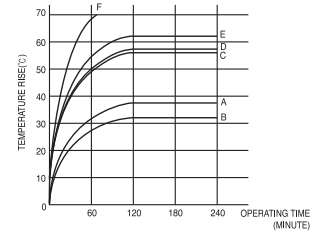

〈Fig.6〉 INTERMITTENT OPERATION OF S7R15GD(WITHOUT GEAR HEAD)

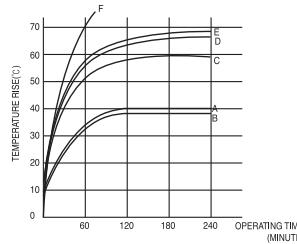

〈Fig.7〉 INTERMITTENT OPERATION OF S8R25GD(WITHOUT GEAR HEAD)

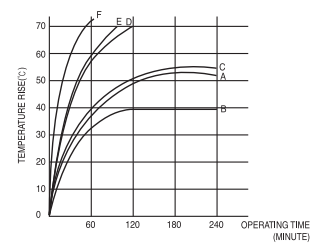

〈Fig.8〉 INTERMITTENT OPERATION OF S9R40GD(WITHOUT GEAR HEAD)

TEMPERATURE CURVE	TYPE OF HEAT RADIATION PLATE		
	DIAMETER(mm)	MATERIAL	PAINTING
L	—	—	—
M	200	IRON	NO PAINTING
N	200	ALUMINUM	NO PAINTING
O	400	IRON	NO PAINTING
P	400	ALUMINUM	NO PAINTING
Q	400	ALUMINUM	BLACK

〈Table2〉 TYPE OF HEAT RADIATION PLATE (THICK 1.5mm)

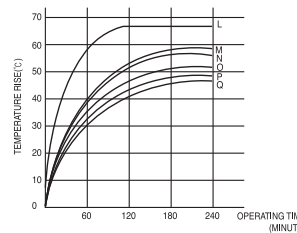

〈Fig.9〉 INTERMITTENT OPERATION OF S8R25GD + S8KA50B + HEAT RADIATION PLATE

### 4. External Structure

- The CE marked reversible motor has a cover 'A' assembled to the back side of the motor to improve dust-proof and water-proof. (Refer to the figure below)
- As a result, the motor is 4.0mm longer than induction motor lengthwise, which requires the user's attention.

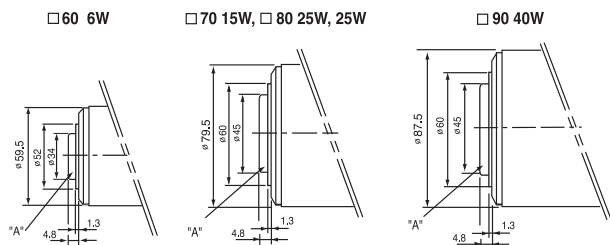

### GENERAL SPECIFICATION OF REVERSIBLE MOTORS

ITEM	Specification
Insulation Resistance	100M $\Omega$ or more when 500V megger is applied between the windings and the housing after rated motor operation under normal ambient temperature and humidity
Dielectric Strength	Sufficient to withstand 1500V at 50/60Hz applied between the windings and the case after rated motor operation under normal ambient temperature and humidity for 1min.
Temperature Rise	80°C or less increase measured by thermometer after rated operation.
Insulation Class	Class B(130°C)
Overheat Protection Device	Built-in thermal protector (automatic return type) : Open 120°C $\pm$ 5°C Close 76°C $\pm$ 15°C
Ambient Temperature	-10°C ~ 40°C
Ambient Humidity	85% maximum(non condensing)





# 6W

REVERSIBLE MOTOR □60mm LEAD WIRE TYPE

SIZE mm sq.	Type	Poles	Output (W)	Voltage (V)	Frequency (Hz)	Duty	Rated Load				Starting Torque		Capacitor (uF)
							Current (A)	Speed (rpm)	Torque (kg-cm) (N-m)		(kg-cm)	(N-m)	
60	S6R06GA S6R06GACE	4	6	1 ∅ 110	60	30min.	0.22	1550	0.40	0.040	0.60	0.060	3.0
	S6R06GB S6R06GBCE	4	6	1 ∅ 220	60	30min.	0.11	1550	0.40	0.040	0.60	0.060	0.8
	S6R06GC S6R06GCCCE	4	6	1 ∅ 100	50 60	30min.	0.21	1200 1500	0.50 0.42	0.050 0.042	0.45	0.045	3.0
	S6R06GD S6R06GDCE	4	6	1 ∅ 200	50 60	30min.	0.10	1200 1500	0.45 0.42	0.045 0.042	0.53	0.053	0.8
	S6R06GE S6R06GECE	4	5.5	1 ∅ 100	50	30min.	0.19	1200	0.50	0.050	0.52	0.052	3.5
	5.4		60		0.22		1500	0.30	0.030				
	6		1 ∅ 115	60	0.18		1500	0.42	0.042	0.50	0.050		
	S6R06GX S6R06GXCE	4	5.8	1 ∅ 220	50	30min.	0.09	1200	0.47	0.047	0.50	0.050	0.7
	6	1 ∅ 240	0.10	0.50			0.050		0.55	0.055			

- ❖ S6R06GE is UL approved (UL FILE No. E172722) impedance protected type.
- ❖ Appropriate capacitors shall be used according to the voltage for S6R06GE type since the size of the capacitor differs by different voltages. Malfunction may occur when not used properly. Capacitor for 115V will be delivered otherwise the required voltage is informed.
- ❖ CE marked at the end of model name indicates that it is impedance protected type which has received CE. S6R06GECE is available only for 115V specification.
- ❖ Data is measured with friction brake mounted.
- ❖ "L" or "H" type does not apply to motors under 40W.

## 50Hz

GEAR RATIO		3	3.6	5	6	7.5	9	10	12.5	15	18	20	25	30	36	40	50	60	75	90	100	120	150	180	200	250
MODEL	rpm	500	416	300	250	200	166	150	120	100	83	75	60	50	41	37	30	25	20	16	15	12	10	8	7.5	6
	kg-Cm	1.3	1.5	2.1	2.6	3.2	3.9	4.3	5.4	6.4	7.7	7.7	9.7	11.6	13.9	15.5	17.5	21.0	26.2	30.0	30.0	30.0	30.0	30.0	30.0	30.0
S6DA□B	N·m	0.127	0.147	0.206	0.255	0.314	0.382	0.421	0.529	0.627	0.755	0.755	0.951	1.137	1.362	1.519	1.715	2.058	2.568	2.942	2.942	2.942	2.942	2.942	2.942	2.942

## 60Hz

GEAR RATIO		3	3.6	5	6	7.5	9	10	12.5	15	18	20	25	30	36	40	50	60	75	90	100	120	150	180	200	250
MODEL	rpm	600	500	360	300	240	200	180	144	120	100	90	72	60	50	45	36	30	24	20	18	15	12	10	9	7.2
	kg-Cm	1.0	1.3	1.7	2.1	2.6	3.1	3.5	4.4	5.2	6.3	6.3	7.8	9.4	11.3	12.6	14.2	17.0	21.3	25.5	28.4	30.0	30.0	30.0	30.0	30.0
S6DA□B	N·m	0.098	0.127	0.167	0.206	0.255	0.304	0.343	0.431	0.510	0.617	0.617	0.764	0.921	1.107	1.235	1.392	1.666	2.087	2.499	2.783	2.942	2.942	2.942	2.942	2.942

- ❖ The code in □ of gearhead model is for gear ratio.
- ❖ It is the permissible torque of the assembled motor and gearhead.
- ❖ The permissible torque of the motor and inter-decimal gearhead is 30 kg-cm.
- ❖ ■ color indicates that the output shaft of the geared motor rotates in the same direction as the output shaft of the motor. Others indicate rotation in the opposite direction.
- ❖ Rpm is based on synchronous speed (50Hz: 1500rpm, 60Hz: 1800rpm) divided by gear ratio. The actual rotation speed can be 2~20% less than displayed value depending on the load.
- ❖ "L" or "H" type does not apply to motors under 40W.

# DIMENSIONS

## + GEARED MOTOR

\* MOTOR MODEL : S6R06G□  
 \* HEAD MODEL : S6□A3□~S6□A250□

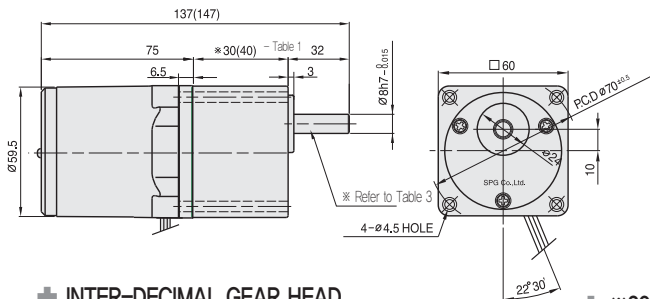

## + INTER-DECIMAL GEAR HEAD

\* MODEL : S6GX10B

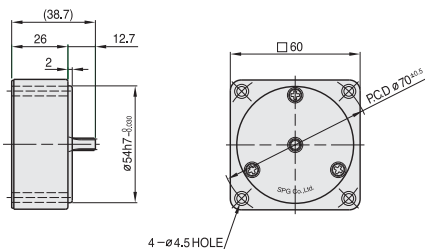

## + \*26(35) - (Table 1)

GEAR RATIO	SIZE(mm)
S6□A3□ ~ S6□A18□	30
S6□A20□ ~ S6□A250□	40

## + WEIGHT - (Table 2)

PART	WEIGHT(kg)	
MOTOR	0.70	
DECIMAL GEAR HEAD	0.18	
GEAR HEAD	S6□A3□ ~ S6□A18□	0.24
	S6□A20□ ~ S6□A40□	0.30
	S6□A50□ ~ S6□A250□	0.33

## + MOTOR

\* MOTOR MODEL : S6R06□□

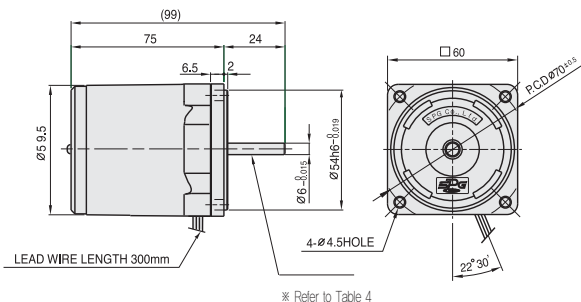

## + SPEC for output shaft of gearhead - (Table 3)

MODEL	TYPES OF OUTPUT SHAFT
STRAIGHT TYPE	
S6SA3□ ~ S6SA250□	
D-CUT TYPE	
S6DA3□ ~ S6DA250□	
KEY TYPE	
S6KA3□ ~ S6KA250□	

## + SPEC for output shaft of motor - (Table 4)

MODEL	TYPES OF OUTPUT SHAFT
GEAR TYPE	
S6R06G□	
STRAIGHT TYPE	
S6R06S□	
D-CUT TYPE	
S6R06D□	

## + KEY SPEC

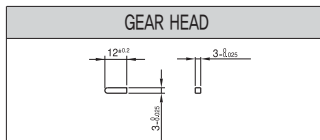

# SCHEMATIC DIAGRAMS

The direction of motor rotation is as viewed from the front shaft end of the motor.

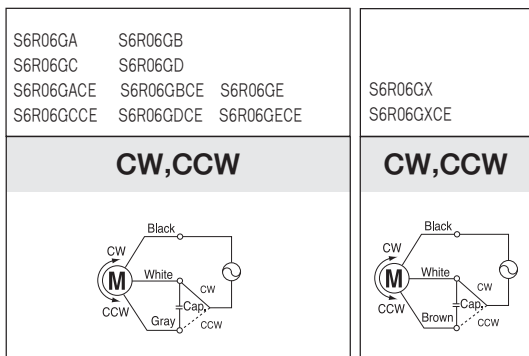



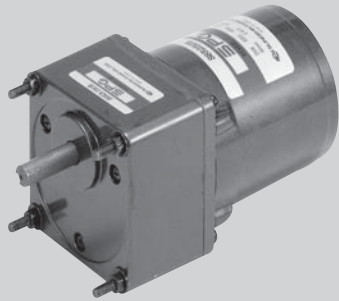

# 15W

## REVERSIBLE MOTOR □ 70mm LEAD WIRE TYPE

SIZE mm sq.	Type	Poles	Output (W)	Voltage (V)	Frequency (Hz)	Duty	Rated Load				Starting Torque		Capacitor (uF)
							Current (A)	Speed (rpm)	Torque (kg-cm) (N-m)		(kg-cm)	(N-m)	
70	S7R15GA S7R15GA(TP) S7R15GACE	4	15	1 ∅ 110	60	30min.	0.44	1550	1.00	0.100	1.10	0.110	6.0
	S7R15GB S7R15GB(TP) S7R15GBCE	4	15	1 ∅ 220	60	30min.	0.22	1550	1.00	0.100	1.10	0.110	1.5
	S7R15GC S7R15GC(TP) S7R15GCCE	4	15	1 ∅ 100	50 60	30min.	0.42 0.42	1200 1500	1.25 1.00	0.125 0.100	0.90 0.90	0.090 0.090	6.0
	S7R15GD S7R15GD(TP) S7R15GDCE	4	15	1 ∅ 200	50 60	30min.	0.21 0.21	1200 1500	1.25 1.00	0.125 0.100	0.90 0.90	0.090 0.090	1.5
	S7R15GE S7R15GECE	4	15	1 ∅ 100 1 ∅ 115	50 60 60	30min.	0.37 0.41 0.35	1200 1500 1550	1.25 1.00 1.00	0.125 0.100 0.100	0.95	0.095	6.0 4.5
	S7R15GX S7R15GXCE	4	15	1 ∅ 220 1 ∅ 240	50	30min.	0.17 0.18	1200	1.25 1.45	0.125 0.145	0.90 1.10	0.090 0.110	1.2

- ❖ S7R15GE is UL approved (UL FILE No. E172720) thermally protected type.
- ❖ Appropriate capacitors shall be used according to the voltage for S7R15GE type since the size of the capacitor differs by different voltages. Malfunction may occur when not used properly. Capacitor for 115V will be delivered otherwise the required voltage is informed.
- ❖ CE marked at the end of model name indicates that it is thermally protected type which has received CE with built-in TP. S7R15GECE is available only for 115V specification.
- ❖ TP marked at the end of the model name indicates that it is standard motor with Thermal Protector mounted. S7R15GE, S7R15GX is thermally protected type with TP mounted.
- ❖ Data is measured with friction brake mounted.
- ❖ "L" or "H" type does not apply to motors under 40W.

## 50Hz

MODEL	GEAR RATIO	GEAR RATIO																							
		3	3.6	5	6	7.5	9	10	12.5	15	18	20	25	30	36	40	50	60	75	90	100	120	150	180	200
S7KA□B	rpm	500	416	300	250	200	166	150	120	100	83	75	60	50	41	37	30	25	20	16	15	12	10	8	7.5
	kg-cm	3.2	3.9	5.4	6.5	8.1	9.7	10.8	13.5	16.2	19.4	19.4	24.2	29.1	34.9	38.8	43.6	50.0	50.0	50.0	50.0	50.0	50.0	50.0	50.0
	N·m	0.314	0.382	0.530	0.637	0.794	0.951	1.059	1.324	1.587	1.902	1.902	2.373	2.854	3.423	3.805	4.276	4.900	4.900	4.900	4.900	4.900	4.900	4.900	4.900

## 60Hz

MODEL	GEAR RATIO	GEAR RATIO																							
		3	3.6	5	6	7.5	9	10	12.5	15	18	20	25	30	36	40	50	60	75	90	100	120	150	180	200
S7KA□B	rpm	600	500	360	300	240	200	180	144	120	100	90	72	60	50	45	36	30	24	20	18	15	12	10	9
	kg-cm	3.0	3.6	5.1	6.1	7.6	9.1	10.1	12.7	15.2	18.2	18.2	22.8	27.3	32.8	36.5	41.0	49.2	50.0	50.0	50.0	50.0	50.0	50.0	50.0
	N·m	0.294	0.353	0.500	0.598	0.745	0.892	0.990	1.245	1.491	1.785	1.785	2.236	2.677	3.217	3.579	4.021	4.825	4.900	4.900	4.900	4.900	4.900	4.900	4.900

- ❖ The code in □ of gearhead model is for gear ratio.
- ❖ It is the permissible torque of the assembled motor and gearhead.
- ❖ The permissible torque of the motor and inter-decimal gearhead is 50 kg-cm.
- ❖ ■ color indicates that the output shaft of the geared motor rotates in the same direction as the output shaft of the motor. Others indicate rotation in the opposite direction.
- ❖ Rpm is based on synchronous speed (50Hz: 1500rpm, 60Hz: 1800rpm) divided by gear ratio. The actual rotation speed can be 2~20% less than displayed value depending on the load.
- ❖ "L" or "H" type does not apply to motors under 40W.

## DIMENSIONS

### GEARED MOTOR

- \* MOTOR MODEL : S7R15G□
- \* HEAD MODEL : S7□A3□~S7□A200□

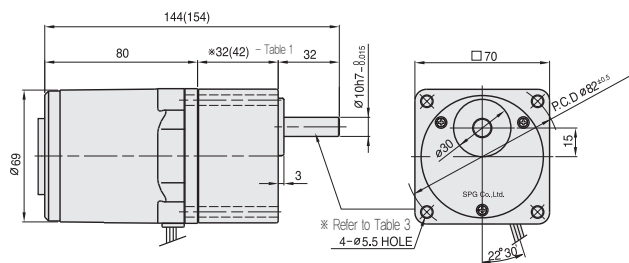

### INTER-DECIMAL GEAR HEAD

- \* MODEL : S7GX10B

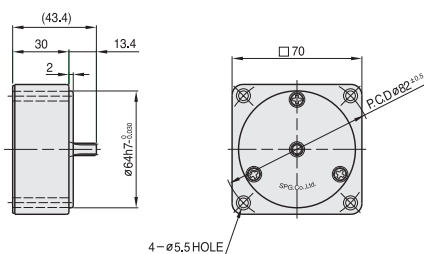

### MOTOR

- \* MOTOR MODEL : S7R15□□

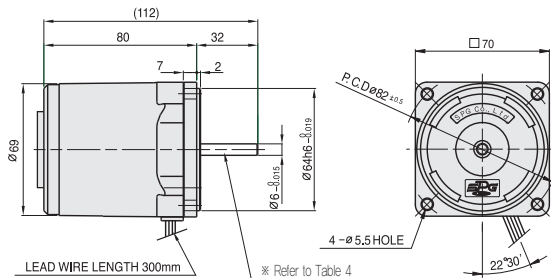

### SPEC for output shaft of gearhead - (Table 3)

MODEL	TYPES OF OUTPUT SHAFT
STRAIGHT TYPE	
S7SA3□ ~S7SA200□	
D-CUT TYPE	
S7DA3□ ~S7DA200□	
KEY TYPE	
S7KA3□ ~S7KA200□	

### \*26(35) - (Table 1)

GEAR RATIO	SIZE(mm)
S7□A3□ ~ S7□A18□	32
S7□A20□ ~ S7□A200□	42

### WEIGHT - (Table 2)

PART	WEIGHT(kg)	
MOTOR	1.04	
DECIMAL GEAR HEAD	0.32	
GEAR HEAD	S7□A3□ ~S7□A18□	0.38
	S7□A20□ ~S7□A40□	0.47
	S7□A50□ ~S7□A200□	0.52

### SPEC for output shaft of motor - (Table 4)

MODEL	TYPES OF OUTPUT SHAFT
GEAR TYPE	
S7R15G□	
STRAIGHT TYPE	
S7R15S□	
D-CUT TYPE	
S7R15D□	

### KEY SPEC

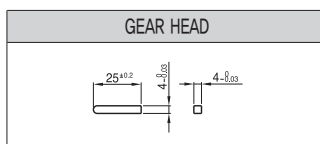

## SCHEMATIC DIAGRAMS

The direction of motor rotation is as viewed from the front shaft end of the motor.

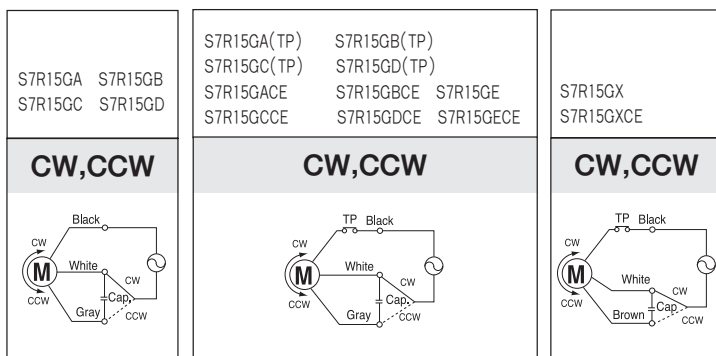



# 15W

REVERSIBLE MOTOR □80mm LEAD WIRE TYPE

SIZE mm sq.	Type	Poles	Output (W)	Voltage (V)	Frequency (Hz)	Duty	Rated Load				Starting Torque		Capacitor (uF)
							Current (A)	Speed (rpm)	Torque (kg-cm) (N-m)		(kg-cm)	(N-m)	
80	S8R15GA S8R15GA(TP) S8R15GACE	4	15	1 ∅ 110	60	30min.	0.49	1550	1.00	0.100	1.20	0.120	6.0
	S8R15GB S8R15GB(TP) S8R15GBCE	4	15	1 ∅ 220	60	30min.	0.25	1550	1.00	0.100	1.20	0.120	1.5
	S8R15GC S8R15GC(TP) S8R15GCCCE	4	15	1 ∅ 100	50	30min.	0.58	1200	1.30	0.130	0.95	0.095	6.0
					60		0.48	1500	1.10	0.110			
	S8R15GD S8R15GD(TP) S8R15GDCE	4	15	1 ∅ 200	50	30min.	0.29	1200	1.30	0.130	0.95	0.095	1.5
					60		0.25	1500	1.10	0.110			
	S8R15GE S8R15GECE	4	15	1 ∅ 100	50	30min.	0.59	1250	1.30	0.130	0.95	0.095	6.0
					60		0.48	1550	1.20	0.120			
					60		0.52	1600	1.10	0.110			
	S8R15GX S8R15GXCE	4	15	1 ∅ 115	60	30min.	0.16	1200	1.30	0.130	1.10	0.110	1.2
				1 ∅ 220	50		0.18		1.40	0.140			
				1 ∅ 240	50		0.18		1.40	0.140			

- ❖ S8R15GE is UL approved (UL FILE No. E172720) thermally protected type.
- ❖ Appropriate capacitors shall be used according to the voltage for S8R15GE type since the size of the capacitor differs by different voltages. Malfunction may occur when not used properly. Capacitor for 115V will be delivered otherwise the required voltage is informed.
- ❖ CE marked at the end of model name indicates that it is thermally protected type which has received CE with built-in TP. S8R15GECE is available only for 115V specification.
- ❖ TP marked at the end of the model name indicates that it is standard motor with Thermal Protector mounted. S8R15GE, S8R15GX is thermally protected type with TP mounted.
- ❖ Data is measured with friction brake mounted.
- ❖ "L" or "H" type does not apply to motors under 40W.

## 50Hz

MODEL	GEAR RATIO	3	3.6	5	6	7.5	9	10	12.5	15	18	20	25	30	36	40	50	60	75	90	100	120	150	180	200
		rpm	500	416	300	250	200	166	150	120	100	83	75	60	50	41	37	30	25	20	16	15	12	10	8
S8KA□B	kg-cm	3.4	4.1	5.7	6.8	8.5	10.2	11.3	14.2	17.0	20.4	20.4	25.6	30.7	36.8	40.9	46.2	55.4	69.2	80	80	80	80	80	80
	N·m	0.333	0.402	0.559	0.666	0.833	1.000	1.107	1.392	1.666	1.999	1.999	2.509	3.009	3.606	4.008	4.530	5.433	6.786	7.840	7.840	7.840	7.840	7.840	7.840

## 60Hz

MODEL	GEAR RATIO	3	3.6	5	6	7.5	9	10	12.5	15	18	20	25	30	36	40	50	60	75	90	100	120	150	180	200
		rpm	600	500	360	300	240	200	180	144	120	100	90	72	60	50	45	36	30	24	20	18	15	12	10
S8KA□B	kg-cm	2.9	3.5	4.9	5.8	7.3	8.7	9.7	12.2	14.6	17.5	17.5	21.9	26.3	31.5	35.0	39.6	47.5	59.4	71.3	79.2	80	80	80	80
	N·m	0.284	0.343	0.481	0.568	0.715	0.853	0.951	1.196	1.432	1.715	1.715	2.146	2.577	3.087	3.430	3.881	4.658	5.825	6.992	7.767	7.840	7.840	7.840	7.840

- ❖ The code in □ of gearhead model is for gear ratio.
- ❖ It is the permissible torque of the assembled motor and gearhead.
- ❖ The permissible torque of the motor and inter-decimal gearhead is 80 kg-cm.
- ❖ ■ color indicates that the output shaft of the geared motor rotates in the same direction as the output shaft of the motor. Others indicate rotation in the opposite direction.
- ❖ Rpm is based on synchronous speed (50Hz: 1500rpm, 60Hz: 1800rpm) divided by gear ratio. The actual rotation speed can be 2~20% less than displayed value depending on the load.
- ❖ "L" or "H" type does not apply to motors under 40W.

## DIMENSIONS

### + GEARED MOTOR

- \* MOTOR MODEL : S8R15G□
- \* HEAD MODEL : S8□A3□~S8□A200□

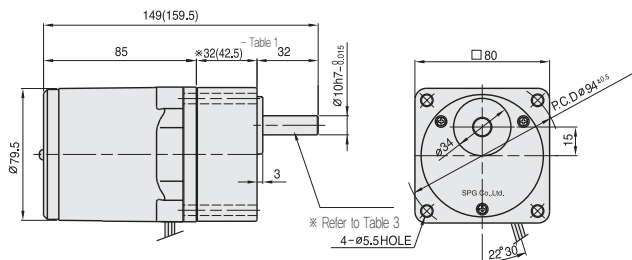

### + INTER-DECIMAL GEAR HEAD

- \* MODEL : S8GX10B

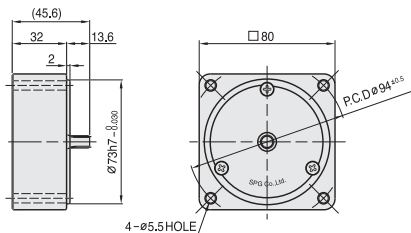

### + MOTOR

- \* MOTOR MODEL : S8R15□□

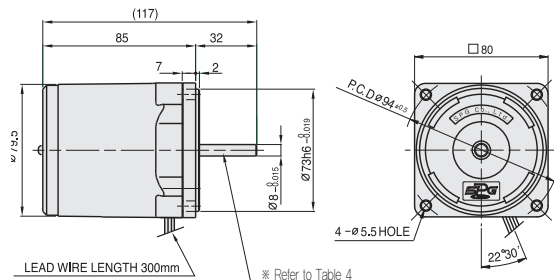

### + SPEC for output shaft of gearhead - (Table 3)

MODEL	TYPES OF OUTPUT SHAFT
STRAIGHT TYPE	
S8SA3□ ~S8SA200□	
D-CUT TYPE	
S8DA3□ ~S8DA200□	
KEY TYPE	
S8KA3□ ~S8KA200□	

### + \*26(35) - (Table 1)

GEAR RATIO	SIZE(mm)
S8□A3□ ~ S8□A18□	32
S8□A20□ ~ S8□A200□	42.5

### + WEIGHT - (Table 2)

PART	WEIGHT(kg)	
MOTOR	1.46	
DECIMAL GEAR HEAD	0.43	
GEAR HEAD	S8□A3□ ~S8□A18□	0.43
	S8□A20□ ~S8□A40□	0.57
	S8□A50□ ~S8□A200□	0.61

### + KEY SPEC

GEAR HEAD	MOTOR

### + SPEC for output shaft of motor - (Table 4)

MODEL	TYPES OF OUTPUT SHAFT
GEAR TYPE	
S8R15G□	
STRAIGHT TYPE	
S8R15S□	
D-CUT TYPE	
S8R15D□	
KEY TYPE	
S8R15K□	

## SCHEMATIC DIAGRAMS

The direction of motor rotation is as viewed from the front shaft end of the motor.

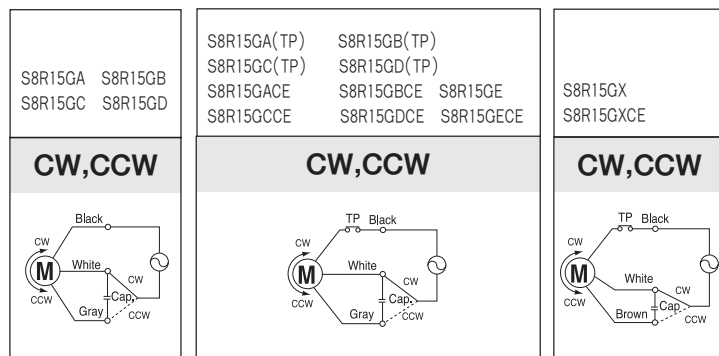

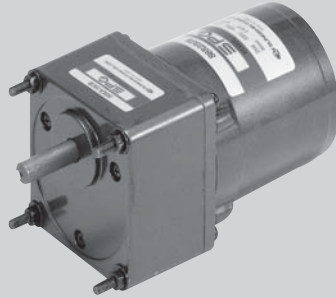

# 25W

REVERSIBLE MOTOR □80mm LEAD WIRE TYPE

SIZE mm sq.	Type	Poles	Output (W)	Voltage (V)	Frequency (Hz)	Duty	Rated Load				Starting Torque		Capacitor (uF)
							Current (A)	Speed (rpm)	Torque (kg-cm) (N-m)		(kg-cm)	(N-m)	
80	S8R25GA S8R25GA(TP) S8R25GACE	4	25	1 ∅ 110	60	30min.	0.71	1550	1.70	0.170	2.30	0.230	10.0
	S8R25GB S8R25GB(TP) S8R25GBCE	4	25	1 ∅ 220	60	30min.	0.35	1600	1.65	0.165	2.30	0.230	2.5
	S8R25GC S8R25GC(TP) S8R25GCCCE	4	25	1 ∅ 100	50 60	30min.	0.63 0.70	1250 1500	2.10 1.70	0.210 0.170	1.80	0.180	10.0
	S8R25GD S8R25GD(TP) S8R25GDCE	4	25	1 ∅ 200	50 60	30min.	0.33	1250 1550	2.10 1.70	0.210 0.170	1.80	0.180	2.5
	S8R25GE S8R25GECE	4	25	1 ∅ 100 1 ∅ 115	50 60	30min.	0.60 0.65 0.63	1250 1450 1550	2.10 1.80 1.70	0.210 0.180 0.170	1.30	0.130	8.0 7.0
	S8R25GX S8R25GXCE	4	25	1 ∅ 220 1 ∅ 240	50	30min.	0.26 0.28	1200	2.00 2.20	0.200 0.220	1.70 2.20	0.170 0.220	2.0

- ❖ S8R25GE is UL approved (UL FILE No. E172720) thermally protected type.
- ❖ Appropriate capacitors shall be used according to the voltage for S8R25GE type since the size of the capacitor differs by different voltages. Malfunction may occur when not used properly. Capacitor for 115V will be delivered otherwise the required voltage is informed.
- ❖ CE marked at the end of model name indicates that it is thermally protected type which has received CE with built-in TP. S8R25GECE is available only for 115V specification.
- ❖ TP marked at the end of the model name indicates that it is standard motor with Thermal Protector mounted. S8R25GE, S8R25GX is thermally protected type with TP mounted.
- ❖ Data is measured with friction brake mounted.
- ❖ "L" or "H" type does not apply to motors under 40W.

## 50Hz

MODEL	GEAR RATIO	GEAR RATIO																							
		3	3.6	5	6	7.5	9	10	12.5	15	18	20	25	30	36	40	50	60	75	90	100	120	150	180	200
S8KA□B	rpm	500	416	300	250	200	166	150	120	100	83	75	60	50	41	37	30	25	20	16	15	12	10	8	7.5
	kg-cm	5.3	6.4	8.9	10.7	13.4	16.0	17.8	22.3	26.7	32.1	32.1	40.2	48.2	57.8	64.2	72.6	80.0	80.0	80.0	80.0	80.0	80.0	80.0	80.0
	N·m	0.519	0.627	0.872	1.049	1.313	1.568	1.744	2.185	2.617	3.146	3.146	3.940	4.724	5.664	6.292	7.115	7.840	7.840	7.840	7.840	7.840	7.840	7.840	7.840

## 60Hz

MODEL	GEAR RATIO	GEAR RATIO																							
		3	3.6	5	6	7.5	9	10	12.5	15	18	20	25	30	36	40	50	60	75	90	100	120	150	180	200
S8KA□B	rpm	600	500	360	300	240	200	180	144	120	100	90	72	60	50	45	36	30	24	20	18	15	12	10	9
	kg-cm	4.4	5.2	7.3	8.7	10.9	13.1	14.6	18.2	21.9	26.2	26.3	32.9	39.4	47.3	52.6	59.4	71.3	80.0	80.0	80.0	80.0	80.0	80.0	80.0
	N·m	0.431	0.510	0.715	0.853	1.068	1.284	1.431	1.784	2.146	2.568	2.577	3.224	3.861	4.635	5.155	5.821	6.987	7.840	7.840	7.840	7.840	7.840	7.840	7.840

- ❖ The code in □ of gearhead model is for gear ratio.
- ❖ It is the permissible torque of the assembled motor and gearhead.
- ❖ The permissible torque of the motor and inter-decimal gearhead is 80 kg-cm.
- ❖ □ color indicates that the output shaft of the geared motor rotates in the same direction as the output shaft of the motor. Others indicate rotation in the opposite direction.
- ❖ Rpm is based on synchronous speed (50Hz: 1500rpm, 60Hz: 1800rpm) divided by gear ratio. The actual rotation speed can be 2~20% less than displayed value depending on the load.
- ❖ "L" or "H" type does not apply to motors under 40W.

# DIMENSIONS

## + GEARED MOTOR

- ※ MOTOR MODEL : S8R25G□
- ※ HEAD MODEL : S8□A3□~S8□A200□

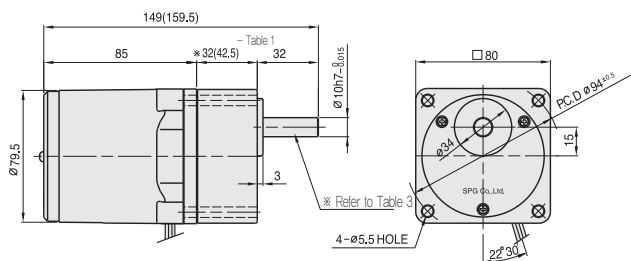

## + INTER-DECIMAL GEAR HEAD

- ※ MODEL : S8GX10B

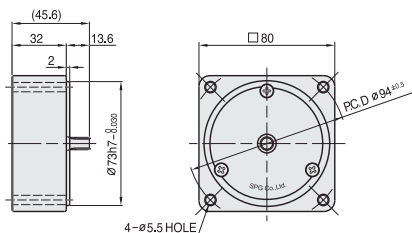

## + MOTOR

- ※ MOTOR MODEL : S8R25□□

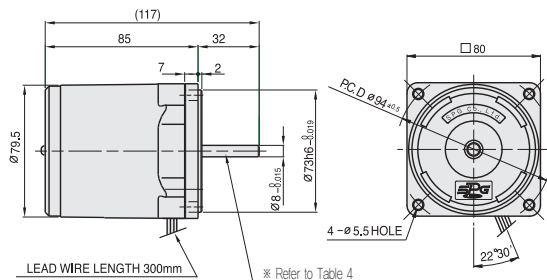

## + SPEC for output shaft of gearhead - (Table 3)

MODEL	TYPES OF OUTPUT SHAFT
STRAIGHT TYPE	
S8SA3□ ~S8SA200□	
D-CUT TYPE	
S8DA3□ ~S8DA200□	
KEY TYPE	
S8KA3□ ~S8KA200□	

## + ※26(35) - (Table 1)

GEAR RATIO	SIZE(mm)
S8□A3□ ~ S8□A18□	32
S8□A20□ ~ S8□A200□	42.5

## + SPEC for output shaft of motor - (Table 4)

MODEL	TYPES OF OUTPUT SHAFT
GEAR TYPE	
S8R25G□	
STRAIGHT TYPE	
S8R25S□	
D-CUT TYPE	
S8R25D□	
KEY TYPE	
S8R25K□	

## + WEIGHT - (Table 2)

PART	WEIGHT(kg)	
MOTOR	1.46	
DECIMAL GEAR HEAD	0.43	
GEAR HEAD	S8□A3□ ~S8□A18□	0.43
	S8□A20□ ~S8□A40□	0.57
	S8□A50□ ~S8□A200□	0.61

## + KEY SPEC

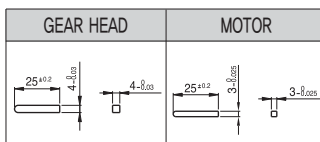

# SCHEMATIC DIAGRAMS

The direction of motor rotation is as viewed from the front shaft end of the motor.

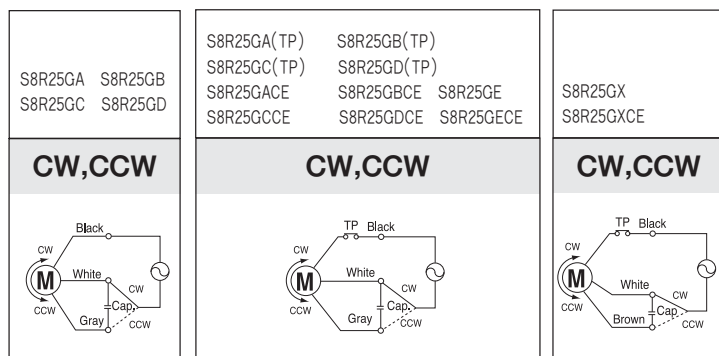



# 40W

REVERSIBLE MOTOR □90mm LEAD WIRE TYPE

SIZE mm sq.	Type	Poles	Output (W)	Voltage (V)	Frequency (Hz)	Duty	Rated Load				Starting Torque		Capacitor (uF)
							Current (A)	Speed (rpm)	Torque (kg-cm) (N-m)		(kg-cm)	(N-m)	
90	S9R40GA( ) S9R40GA( )(TP) S9R40GA( )CE	4	40	1 ∅ 110	60	30min.	1.00	1600	2.50	0.250	3.50	0.350	15.0
	S9R40GB( ) S9R40GB( )(TP) S9R40GB( )CE	4	40	1 ∅ 220	60	30min.	0.46	1600	2.50	0.250	3.50	0.350	3.5
	S9R40GC( ) S9R40GC( )(TP) S9R40GC( )CE	4	40	1 ∅ 100	50 60	30min.	0.84 1.00	1300 1550	3.00 2.60	0.300 0.260	2.80	0.280	15.0
	S9R40GD( ) S9R40GD( )(TP) S9R40GD( )CE	4	40	1 ∅ 200	50 60	30min.	0.39 0.47	1300 1550	3.10 2.60	0.310 0.260	2.80	0.280	3.5
	S9R40GE( ) S9R40GE( )CE	4	40	1 ∅ 100 1 ∅ 115	50 60	30min.	0.86 1.00	1300 1550	3.10 2.60	0.310 0.260	2.90	0.290	15.0 12.0
	S9R40GX( ) S9R40GX( )CE	4	40	1 ∅ 220 1 ∅ 240	60 50	30min.	1.00 0.40 0.42	1550 1250	2.70 3.20 3.40	0.270 0.320 0.340	3.00 3.20	0.300 0.320	3.0

- ❖ S9R40GE is UL approved (UL FILE No. E172720) thermally protected type.
- ❖ Appropriate capacitors shall be used according to the voltage for S9R40GE type since the size of the capacitor differs by different voltages. Malfunction may occur when not used properly. Capacitor for 115V will be delivered otherwise the required voltage is informed.
- ❖ CE marked at the end of model name indicates that it is thermally protected type which has received CE with built-in TP. S9R40GE( )CE is available only for 115V specification.
- ❖ TP marked at the end of the model name indicates that it is standard motor with Thermal Protector mounted. S9R40GE, S9R40GX is thermally protected type with TP mounted.
- ❖ Data is measured with friction brake mounted.
- ❖ ( ) is for marking 'L' type or 'H'. 'L' should be used with gearhead 'L' and 'H' should be used with gearhead 'H'.

## 50Hz

MODEL	GEAR RATIO	GEAR RATIO																								
		3	3.6	5	6	7.5	9	10	12.5	15	18	20	25	30	36	40	50	60	75	90	100	120	150	180	200	
S9KB□( )	rpm	500	416	300	250	200	166	150	120	100	83	75	60	50	41	37	30	25	20	16	15	12	10	8	7.5	
	kg-cm	8.3	9.9	13.8	16.5	20.7	24.8	27.5	34.4	41.3	49.6	49.6	62.1	74.5	89.4	99.3	100	100	100	100	100	100	100	100	100	100
	N·m	0.813	0.970	1.352	1.617	2.029	2.430	2.695	3.371	4.047	4.861	4.861	6.086	7.301	8.761	9.731	9.800	9.800	9.800	9.800	9.800	9.800	9.800	9.800	9.800	9.800

## 60Hz

MODEL	GEAR RATIO	GEAR RATIO																								
		3	3.6	5	6	7.5	9	10	12.5	15	18	20	25	30	36	40	50	60	75	90	100	120	150	180	200	
S9KB□( )	rpm	600	500	360	300	240	200	180	144	120	100	90	72	60	50	45	36	30	24	20	18	15	12	10	9	
	kg-cm	6.8	8.2	11.3	13.6	17.0	20.4	22.7	28.4	34.0	40.8	40.9	51.1	61.3	73.6	81.8	100	100	100	100	100	100	100	100	100	100
	N·m	0.666	0.804	1.107	1.333	1.666	1.999	2.225	2.783	3.332	3.998	4.008	5.008	6.007	7.213	8.016	9.800	9.800	9.800	9.800	9.800	9.800	9.800	9.800	9.800	9.800

- ❖ The code in □ of gearhead model is for gear ratio.
- ❖ It is the permissible torque of the assembled motor and gearhead.
- ❖ The permissible torque of the motor and inter-decimal gearhead is 100 kg-cm.
- ❖ ■ color indicates that the output shaft of the geared motor rotates in the same direction as the output shaft of the motor. Others indicate rotation in the opposite direction.
- ❖ Rpm is based on synchronous speed (50Hz: 1500rpm, 60Hz: 1800rpm) divided by gear ratio. The actual rotation speed can be 2~20% less than displayed speed value depending on the load.
- ❖ ( ) is for marking 'L' type or 'H'. 'L' should be used with motor 'L' and 'H' should be used with motor 'H'.

## DIMENSIONS

### + GEARED MOTOR

- ※ MOTOR MODEL : S9R40G□□
- ※ HEAD MODEL : S9□B3□□~S9□B200□□

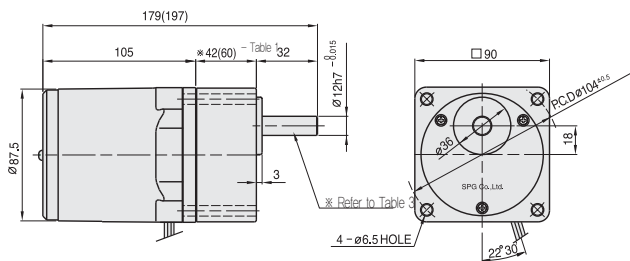

### + INTER-DECIMAL GEAR HEAD

- ※ MODEL : S9GX10B(H,L)

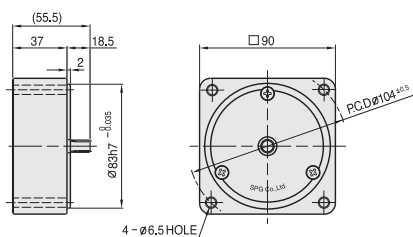

### + MOTOR

- ※ MOTOR MODEL : S9R40□□□

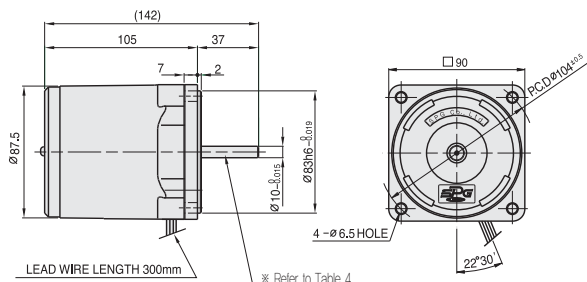

### + ※26(35) - (Table 1)

GEAR RATIO	SIZE(mm)
S9□B3□□ ~ S9□B18□□	42
S9□B20□□ ~ S9□B200□□	60

### + WEIGHT - (Table 2)

PART	WEIGHT(kg)	
MOTOR	2.34	
DECIMAL GEAR HEAD	0.59	
GEAR HEAD	S9□B3□□ ~ S9□B18□□	0.73
	S9□B20□□ ~ S9□B40□□	1.03
	S9□B50□□ ~ S9□B200□□	1.13

### + KEY SPEC

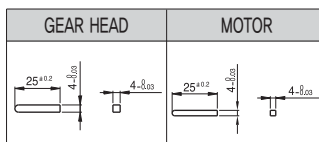

### + SPEC for output shaft of gearhead - (Table 3)

MODEL	TYPES OF OUTPUT SHAFT
STRAIGHT TYPE	
S9SB3□□ ~ S9SB200□□	
D-CUT TYPE	
S9DB3□□ ~ S9DB200□□	
KEY TYPE	
S9KB3□□ ~ S9KB200□□	

### + SPEC for output shaft of motor - (Table 4)

MODEL	TYPES OF OUTPUT SHAFT
GEAR TYPE	
S9R40G□□	
STRAIGHT TYPE	
S9R40S□	
D-CUT TYPE	
S9R40D□	
KEY TYPE	
S9R40K□	

## SCHEMATIC DIAGRAMS

The direction of motor rotation is as viewed from the front shaft end of the motor.

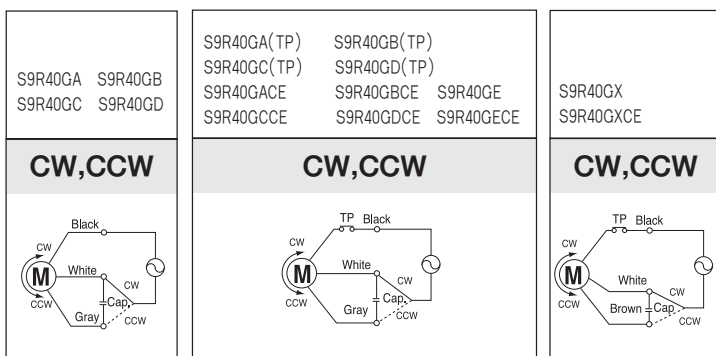



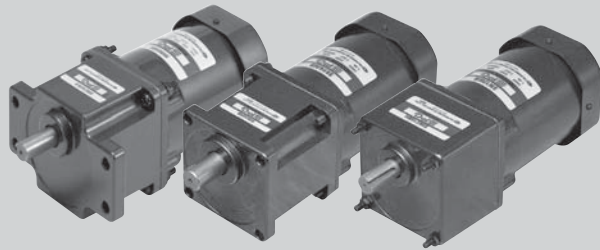

# 60W

REVERSIBLE MOTOR □90mm LEAD WIRE TYPE

SIZE mm sq.	Type	Poles	Output (W)	Voltage (V)	Frequency (Hz)	Duty	Rated Load				Starting Torque		Capacitor (uF)
							Current (A)	Speed (rpm)	Torque (kg-cm) (N-m)		(kg-cm)	(N-m)	
90	S9R60GA( ) S9R60GA( )(TP) S9R60GA( )CE	4	60	1 ∅ 110	60	30min.	1.60	1600	3.80	0.380	7.00	0.700	25.0
	S9R60GB( ) S9R60GB( )(TP) S9R60GB( )CE	4	60	1 ∅ 220	60	30min.	0.75	1600	3.80	0.380	7.00	0.700	6.0
	S9R60GC( ) S9R60GC( )(TP) S9R60GC( )CE	4	60	1 ∅ 100	50	30min.	1.40	1250	4.80	0.480	6.00	0.600	25.0
	60				1.60		1550	3.90	0.390				
	S9R60GD( ) S9R60GD( )(TP) S9R60GD( )CE	4	60	1 ∅ 200	50	30min.	0.70	1250	4.80	0.480	5.50	0.550	6.0
	60				0.76		1550	3.90	0.390				
	S9R60GE( ) S9R60GE( )CE	4	60	1 ∅ 100	50	30min.	1.40	1250	4.80	0.480	5.90	0.590	25.0
	60				1.60		1550	3.90	0.390				
	1 ∅ 115				1.30		1600	3.90	0.390	6.00			
	S9R60GX( ) S9R60GX( )CE	4	60	1 ∅ 220	50	30min.	0.63	1250	4.80	0.480	5.90	0.590	5.0
	1 ∅ 240						0.67		5.00	0.500	6.30	0.630	

- ❖ S9R60GE is UL approved (UL FILE No. E172720) thermally protected type.
- ❖ Appropriate capacitors shall be used according to the voltage for S9R60GE type since the size of the capacitor differs by different voltages. Malfunction may occur when not used properly. Capacitor for 115V will be delivered otherwise the required voltage is informed.
- ❖ CE marked at the end of model name indicates that it is thermally protected type which has received CE with built-in TP.  
S9R60GE( )CE is available only for 115V specification.
- ❖ TP marked at the end of the model name indicates that it is standard motor with Thermal Protector mounted.  
S9R60GE, S9R60GX is thermally protected type with TP mounted.
- ❖ Data is measured with friction brake mounted.
- ❖ ( ) is for marking 'L' type or 'H'. 'L' should be used with gearhead 'L' and 'H' should be used with gearhead 'H'.

## 50Hz

GEAR RATIO		3	3.6	5	6	7.5	9	10	12.5	15	18	20	25	30	36	40	50	60	75	90	100	120	150	180	200
MODEL	rpm	500	416	300	250	200	166	150	120	100	83	75	60	50	41	37	30	25	20	16	15	12	10	8	7.5
	kg-cm	12.2	14.6	20.3	24.3	30.4	36.5	40.5	45.6	54.8	65.7	73.0	82.5	99.0	119	132	165	198	200	200	200	200	200	200	200
S9KC□( )	Nm	1.196	1.431	1.989	2.381	2.989	3.577	3.969	4.469	5.370	6.439	7.154	8.085	9.702	11.66	12.94	16.17	19.40	19.60	19.60	19.60	19.60	19.60	19.60	19.60
S9KC□( )-S																									

## 60Hz

GEAR RATIO		3	3.6	5	6	7.5	9	10	12.5	15	18	20	25	30	36	40	50	60	75	90	100	120	150	180	200
MODEL	rpm	600	500	360	300	240	200	180	144	120	100	90	72	60	50	45	36	30	24	20	18	15	12	10	9
	kg-cm	9.72	11.7	16.2	19.4	24.3	29.2	32.4	36.5	43.8	52.6	58.4	66.0	79.2	95.0	106	132	158	177	200	200	200	200	200	200
S9KC□( )	Nm	0.953	1.147	1.588	1.901	2.381	2.862	3.175	3.577	4.292	5.155	5.723	6.468	7.762	9.310	10.39	12.94	15.48	17.35	19.60	19.60	19.60	19.60	19.60	19.60
S9KC□( )-S																									

- ❖ The code in □ of gearhead model is for gear ratio.
- ❖ It is the permissible torque of the assembled motor and gearhead.
- ❖ The permissible torque of the motor and inter-decimal gearhead is 200 kg-cm.
- ❖ ■ color indicates that the output shaft of the geared motor rotates in the same direction as the output shaft of the motor. Others indicate rotation in the opposite direction.
- ❖ Rpm is based on synchronous speed (50Hz: 1500rpm, 60Hz: 1800rpm) divided by gear ratio.  
The actual rotation speed can be 2~20% less than displayed value depending on the load.
- ❖ ( ) is for marking 'L' type or 'H'. 'L' should be used with motor 'L' and 'H' should be used with motor 'H'.

# DIMENSIONS

## + GEARED MOTOR

\* MOTOR MODEL : S9R60G□□  
 \* HEAD MODEL : S9□C3B□-S-S9□C200B□-S

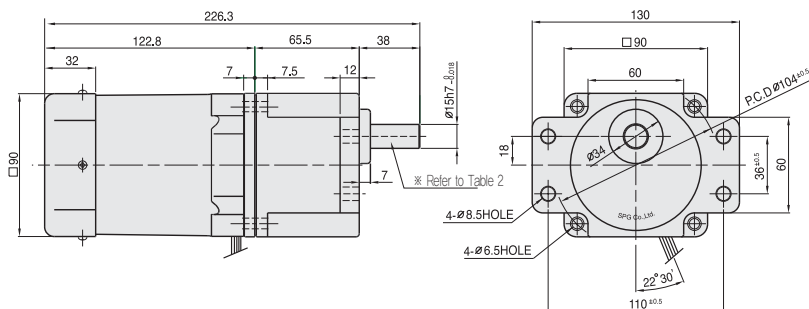

\* HEAD MODEL : S9□C3B□~S9□C200B□

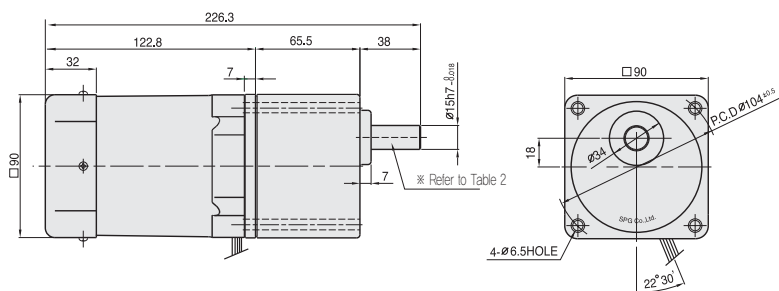

## + MOTOR

\* MOTOR MODEL : S9R60□□□

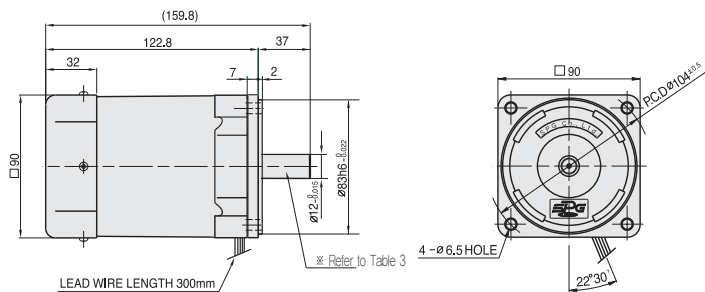

## + INTER-DECIMAL GEAR HEAD

\* MODEL : S9GX10B(H,L)-S

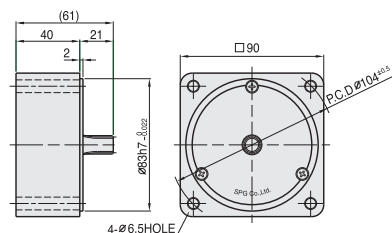

## + WEIGHT - (Table 1)

PART	WEIGHT(kg)	
MOTOR	2.48	
DECIMAL GEAR HEAD	0.65	
GEAR HEAD	S9□C3B□ ~S9□C10B□	1.21
	S9□C12.5B□ ~S9□C20B□	1.30
	S9□C25B□ ~S9□C60B□	1.40
	S9□C75B□ ~S9□C200B□	1.45

## + KEY SPEC

GEAR HEAD	MOTOR

## + SPEC for output shaft of gearhead - (Table 2)

MODEL	TYPES OF OUTPUT SHAFT
STRAIGHT TYPE S9SC3B□ ~S9SC200B□	
D-CUT TYPE S9DC3B□ ~S9DC200B□	
KEY TYPE S9KC3B□ ~S9KC200B□	

## + SPEC for output shaft of motor - (Table 3)

MODEL	TYPES OF OUTPUT SHAFT
GEAR TYPE S9R60G□□	
STRAIGHT TYPE S9R60S□	
D-CUT TYPE S9R60D□	
KEY TYPE S9R60□	

## DIMENSIONS

**+ GEARED MOTOR** ※ MOTOR MODEL : S9R60□H  
 ※ HEAD MODEL : S9□D3B~S9□D200B

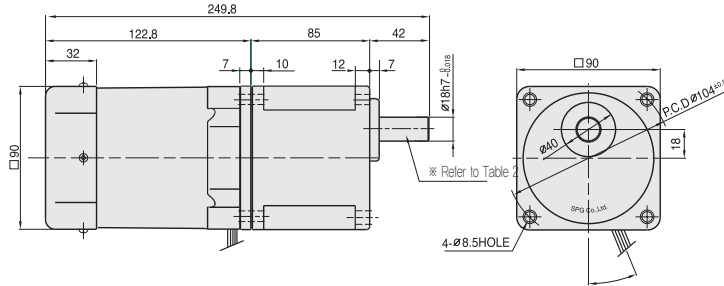

**+ WEIGHT - (Table 1)**

PART		WEIGHT(kg)
MOTOR		2.48
GEAR HEAD	S9□D3B ~S9□D10B	1.65
	S9□D12.5B ~S9□D20B	1.80
	S9□D25B ~S9□D60B	1.90
	S9□D75B ~S9□D200B	1.95

**+ KEY SPEC**

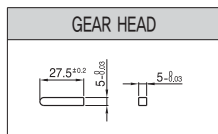

**+ SPEC for output shaft of gearhead - (Table 2)**

MODEL	TYPES OF OUTPUT SHAF	MODEL	TYPES OF OUTPUT SHAF	MODEL	TYPES OF OUTPUT SHAF
STRAIGHT TYPE		D-CUT TYPE		KEY TYPE	
S9SD3B ~S9SD200B		S9DD3B ~S9DD200B		S9KD3B ~S9KD200B	

## 50Hz

GEAR RATIO	MODEL																								
	rpm	500	416	300	250	200	166	150	120	100	83	75	60	50	41	37	30	25	20	16	15	12	10	8	7.5
S9KD□B	kg-cm	12.2	14.6	20.3	24.3	30.4	36.5	40.5	45.6	54.8	65.7	73.0	82.5	99.0	119	132	165	198	221	266	295	300	300	300	300
	N·m	1.196	1.431	1.989	2.381	2.989	3.577	3.969	4.469	5.370	6.439	7.154	8.085	9.702	11.66	12.94	16.17	19.40	21.67	26.09	28.93	29.42	29.42	29.42	29.42

## 60Hz

GEAR RATIO	MODEL																								
	rpm	600	500	360	300	240	200	180	144	120	100	90	72	60	50	45	36	30	24	20	18	15	12	10	9
S9KD□B	kg-cm	9.72	11.7	16.2	19.4	24.3	29.2	32.4	36.5	43.8	52.6	58.4	66.0	79.2	95.0	106	132	158	177	212	236	283	300	300	300
	N·m	0.953	1.147	1.588	1.901	2.381	2.862	3.175	3.577	4.292	5.155	5.723	6.468	7.762	9.310	10.39	12.94	15.48	17.35	20.79	23.14	27.75	29.42	29.42	29.42

- ❖ The code in □ of gearhead model is for gear ratio.
- ❖ It is the permissible torque of the assembled motor and gearhead.
- ❖ The permissible torque of the motor and inter-decimal gearhead is 300 kg-cm.
- ❖ ■ color indicates that the output shaft of the geared motor rotates in the same direction as the output shaft of the motor. Others indicate rotation in the opposite direction.
- ❖ Rpm is based on synchronous speed (50Hz: 1500rpm, 60Hz: 1800rpm) divided by gear ratio. The actual rotation speed can be 2~20% less than displayed value depending on the load.
- ❖ Only "H" type is applicable. Please use "H" type motor.

## SCHEMATIC DIAGRAMS

The direction of motor rotation is as viewed from the front shaft end of the motor.

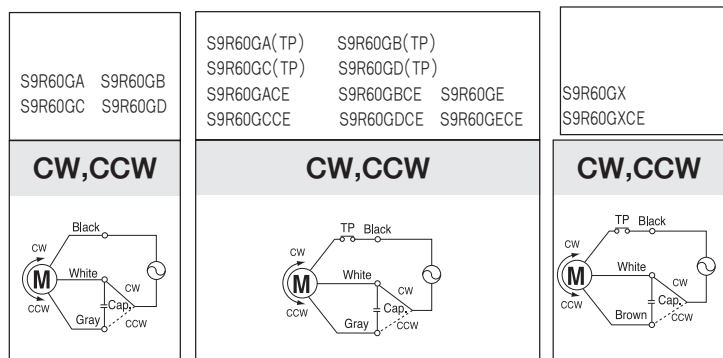

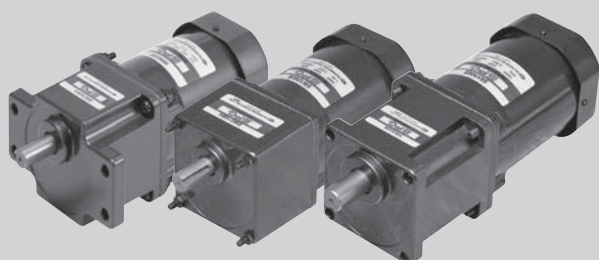

# 90W

REVERSIBLE MOTOR □ 90mm LEAD WIRE TYPE

SIZE mm sq.	Type	Poles	Output (W)	Voltage (V)	Frequency (Hz)	Duty	Rated Load				Starting Torque		Capacitor (uF)
							Current (A)	Speed (rpm)	Torque (kg-cm) (N-m)		(kg-cm)	(N-m)	
90	S9R90GA( ) S9R90GA( )(TP) S9R90GA( )CE	4	90	1 ∅ 110	60	30min.	2.25	1550	5.80	0.580	8.50	0.850	30.0
	S9R90GB( ) S9R90GB( )(TP) S9R90GB( )CE	4	90	1 ∅ 220	60	30min.	1.00	1550	5.80	0.580	8.50	0.850	7.0
	S9R90GC( ) S9R90GC( )(TP) S9R90GC( )CE	4	90	1 ∅ 100	50 60	30min.	2.10 2.25	1200 1500	7.50 6.00	0.750 0.600	6.50	0.650	30.0
	S9R90GD( ) S9R90GD( )(TP) S9R90GD( )CE	4	90	1 ∅ 200	50 60	30min.	0.90 1.00	1200 1500	7.50 6.00	0.750 0.600	6.50	0.650	7.0
	S9R90GE( ) S9R90GE( )CE	4	90	1 ∅ 100 1 ∅ 115	50 60	30min.	1.80 1.90	1200 1500	7.50 6.00	0.750 0.600	6.50	0.650	30.0
	S9R90GX( ) S9R90GX( )CE	4	90	1 ∅ 220 1 ∅ 240	60 50	30min.	0.82 0.86	1550 1250	6.00 7.40	0.600 0.740	8.00 8.00	0.800 0.800	25.0 6.0

- ❖ S9R90GE is UL approved (UL FILE No. E172720) thermally protected type.
- ❖ Appropriate capacitors shall be used according to the voltage for S9R90GE type since the size of the capacitor differs by different voltages. Malfunction may occur when not used properly. Capacitor for 115V will be delivered otherwise the required voltage is informed.
- ❖ CE marked at the end of model name indicates that it is thermally protected type which has received CE with built-in TP. S9R90GE( )CE is available only for 115V specification.
- ❖ TP marked at the end of the model name indicates that it is standard motor with Thermal Protector mounted. S9R90GE, S9R90GX is thermally protected type with TP mounted.
- ❖ Data is measured with friction brake mounted.
- ❖ ( ) is for marking 'L' type or 'H'. 'L' should be used with gearhead 'L' and 'H' should be used with gearhead 'H'.

## 50Hz

GEAR RATIO	3 3.6 5 6 7.5 9 10 12.5 15 18 20 25 30 36 40 50 60 75 90 100 120 150 180 200																										
	MODEL	rpm	500	416	300	250	200	166	150	120	100	83	75	60	50	41	37	30	25	20	16	15	12	10	8	7.5	
S9KC□( )	kg-cm	18.2	21.9	30.4	36.5	45.6	54.7	60.8	68.4	82.1	98.6	110	124	149	178	198	200	200	200	200	200	200	200	200	200	200	200
S9KC□( )-S	Nm	1.784	2.146	2.979	3.577	4.469	5.361	5.958	6.703	8.046	9.663	10.78	12.15	14.60	17.44	19.40	19.60	19.60	19.60	19.60	19.60	19.60	19.60	19.60	19.60	19.60	19.60

## 60Hz

GEAR RATIO	3 3.6 5 6 7.5 9 10 12.5 15 18 20 25 30 36 40 50 60 75 90 100 120 150 180 200																									
	MODEL	rpm	600	500	360	300	240	200	180	144	120	100	90	72	60	50	45	36	30	24	20	18	15	12	10	9
S9KC□( )	kg-cm	14.6	17.5	24.3	29.2	36.5	43.7	48.6	54.8	65.7	78.8	87.6	99.0	119	143	158	198	200	200	200	200	200	200	200	200	200
S9KC□( )-S	Nm	1.431	1.715	2.381	2.862	3.577	4.675	4.763	5.370	6.439	7.722	8.585	9.702	11.66	14.01	15.48	19.40	19.60	19.60	19.60	19.60	19.60	19.60	19.60	19.60	19.60

- ❖ The code in □ of gearhead model is for gear ratio.
- ❖ It is the permissible torque of the assembled motor and gearhead.
- ❖ The permissible torque of the motor and inter-decimal gearhead is 200 kg-cm.
- ❖ ■ color indicates that the output shaft of the geared motor rotates in the same direction as the output shaft of the motor. Others indicate rotation in the opposite direction.
- ❖ Rpm is based on synchronous speed (50Hz: 1500rpm, 60Hz: 1800rpm) divided by gear ratio. The actual rotation speed can be 2~20% less than displayed value depending on the load.
- ❖ ( ) is for marking 'L' type or 'H'. 'L' should be used with motor 'L' and 'H' should be used with motor 'H'.

## DIMENSIONS

### + GEARED MOTOR

- \* MOTOR MODEL : S9R90G□□
- \* HEAD MODEL : S9□C3B□-S-S9□C200B□-S

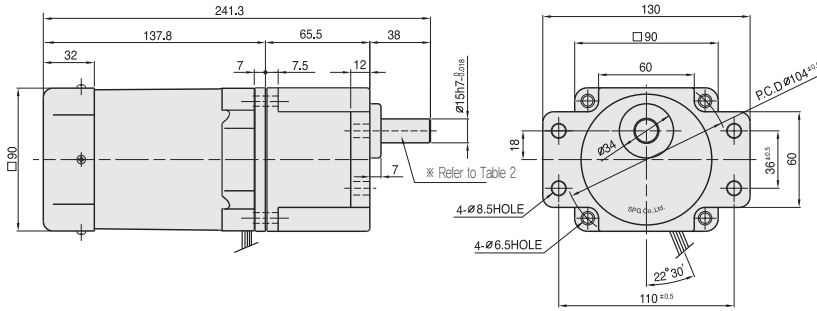

- \* HEAD MODEL : S9□C3B□~S9□C200B□

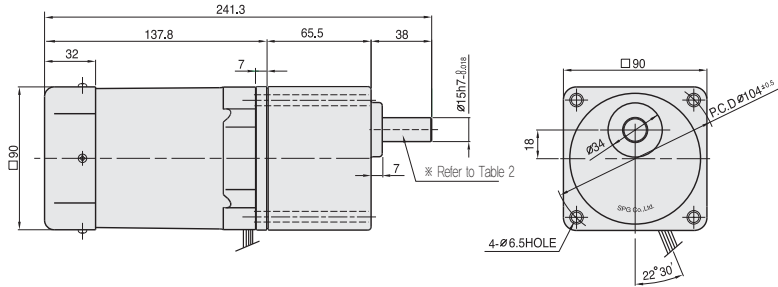

### + MOTOR

- \* MOTOR MODEL : S9R90□□□

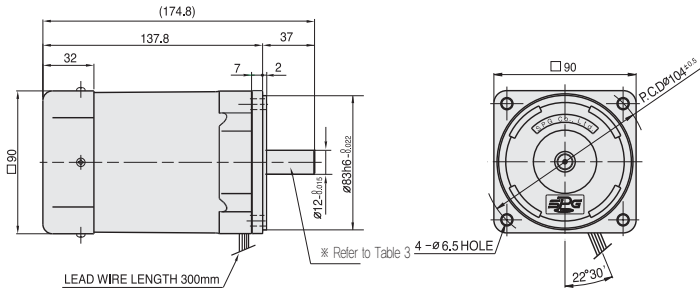

### + INTER-DECIMAL GEAR HEAD

- \* MODEL : S9GX10B(H,L)-S

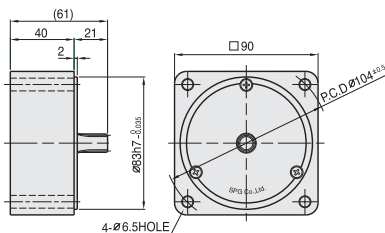

### + WEIGHT - (Table 1)

PART	WEIGHT(kg)	
MOTOR	2.93	
DECIMAL GEAR HEAD	0.65	
GEAR HEAD	S9□C3B□ ~S9□C10B□	1.21
	S9□C12.5B□ ~S9□C20B□	1.30
	S9□C25B□ ~S9□C60B□	1.40
	S9□C75B□ ~S9□C200B□	1.45

### + KEY SPEC

GEAR HEAD	MOTOR

### + SPEC for output shaft of gearhead - (Table 2)

MODEL	TYPES OF OUTPUT SHAFT
STRAIGHT TYPE	
S9SC3B□ ~S9SC200B□	
D-CUT TYPE	
S9DC3B□ ~S9DC200B□	
KEY TYPE	
S9KC3B□ ~S9KC200B□	

### + SPEC for output shaft of motor - (Table 3)

MODEL	TYPES OF OUTPUT SHAFT
GEAR TYPE	
S9R90G□□	
STRAIGHT TYPE	
S9R90S□	
D-CUT TYPE	
S9R90D□	
KEY TYPE	
S9R90K□	

## DIMENSIONS

- GEARED MOTOR ※ MOTOR MODEL : S9I90G□H  
 ※ HEAD MODEL : S9□D3B-S9□D200B

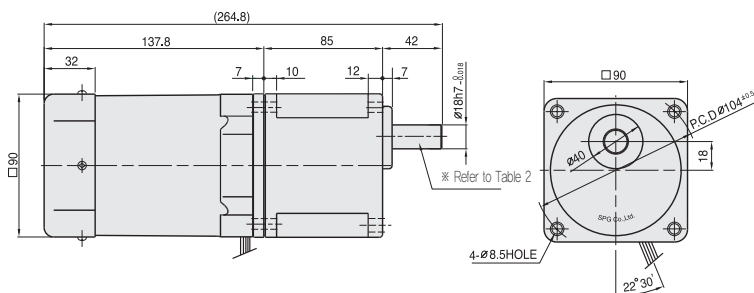

### WEIGHT - (Table 1)

PART		WEIGHT(kg)
MOTOR		2.99
GEAR HEAD	S9□D3B ~S9□D10B	1.65
	S9□D12.5B ~S9□D20B	1.80
	S9□D25B ~S9□D60B	1.90
	S9□D75B ~S9□D200B	1.95

### KEY SPEC

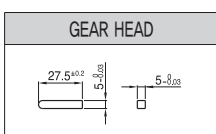

### SPEC for output shaft of gearhead - (Table 2)

MODEL	TYPES OF OUTPUT SHAF	MODEL	TYPES OF OUTPUT SHAF	MODEL	TYPES OF OUTPUT SHAF
STRAIGHT TYPE S9SD3B ~S9SD200B		D-CUT TYPE S9DD3B ~S9DD200B		KEY TYPE S9KD3B ~S9KD200B	

## 50Hz

GEAR RATIO	MODEL																								
	rpm	500	416	300	250	200	166	150	120	100	83	75	60	50	41	37	30	25	20	16	15	12	10	8	7.5
S9KD□B	kg-cm	18.2	21.9	30.4	36.5	45.6	54.7	60.8	68.4	82.1	98.6	110	124	149	178	198	248	297	300	300	300	300	300	300	300
	N·m	1.784	2.146	2.979	3.577	4.469	5.361	5.958	6.703	8.046	9.663	10.78	12.15	14.60	17.44	19.40	24.32	29.13	29.42	29.42	29.42	29.42	29.42	29.42	29.42

## 60Hz

GEAR RATIO	MODEL																								
	rpm	600	500	360	300	240	200	180	144	120	100	90	72	60	50	45	36	30	24	20	18	15	12	10	9
S9KD□B	kg-cm	14.6	17.5	24.3	29.2	36.5	43.7	48.6	54.8	65.7	78.8	87.6	99.0	119	143	158	198	238	266	300	300	300	300	300	300
	N·m	1.431	1.715	2.381	2.862	3.577	4.675	4.763	5.370	6.439	7.722	8.585	9.702	11.66	14.01	15.48	19.40	23.34	26.09	29.42	29.42	29.42	29.42	29.42	29.42

- ❖ The code in □ of gearhead model is for gear ratio.
- ❖ It is the permissible torque of the assembled motor and gearhead.
- ❖ The permissible torque of the motor and inter-decimal gearhead is 300 kg-cm.
- ❖ ■ color indicates that the output shaft of the geared motor rotates in the same direction as the output shaft of the motor. Others indicate rotation in the opposite direction.
- ❖ Rpm is based on synchronous speed (50Hz: 1500rpm, 60Hz: 1800rpm) divided by gear ratio. The actual rotation speed can be 2~20% less than displayed value depending on the load.
- ❖ Only "H" type is applicable. Please use "H" type motor.

## SCHEMATIC DIAGRAMS

The direction of motor rotation is as viewed from the front shaft end of the motor.

